



A Micromachined Comb-Drive Tuning Fork Rate Gyroscope

Introduction

This tutorial model of a comb-drive tuning fork gyroscope is kindly provided by Dr. James Ransley at Veryst Engineering, LLC. The model demonstrates fully parameterized geometry, extensive use of selection features, implementation of analytic formulas for the electromechanical forces and response estimation, and comparison of numerical results with analytical estimations. In particular, extrusion operators are used to compute the distances between electrodes for force calculation. The device is loosely based on [Ref. 1](#).

Model Definition

The geometry of the device is shown in the figure below. All dimensions and numbers of etch holes and comb fingers are parameterized in the model. Various selection features are used for the construction of the geometry and the setup of position-dependent variables, physics, and mesh.

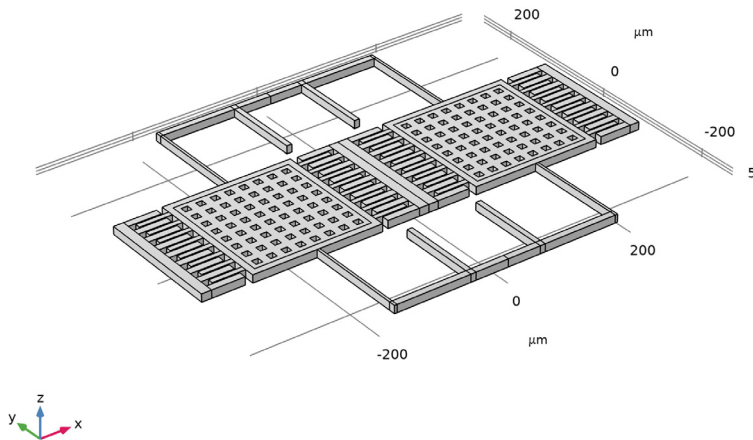

Figure 1: The geometry of the gyroscope.

The gyroscope is composed of two proof masses supported by springs anchored to the substrate (not explicitly modeled). The comb drive excites the drive mode with the two masses oscillating along the X -axis in opposite directions. The device is designed to sense rotations around the Y -axis. The combination of such rotations and the drive-mode motion causes a Coriolis force in the positive and negative Z directions, which excites the out-of-plane sense-mode oscillation of the two masses. The sense-mode oscillation is picked up capacitively with electrodes in the substrate.

The combs are assumed to be DC-biased at 60 V and AC-excited at 3 V. The sense electrodes are assumed to be DC-biased at 5 V. While a predefined Electromechanics multiphysics coupling is available with the MEMS Module, this model demonstrates the use of analytic formulas for computing the electrostatic forces.

The implementation of the parallel plate capacitor forces in the model is based on the expression for the force per unit area between two parallel plates of infinite extent with a dielectric medium of relative permittivity 1 (air or vacuum) in between:

$$F_A = \frac{\epsilon_0 V^2}{2d^2} \quad (1)$$

Here, ϵ_0 is the permittivity of free space and d is the distance between the plates. This work uses this formula locally to approximate the forces between electrodes even when the plates are slightly misaligned, or near the edges of a structure where fringing fields might be important. These approximations make the model much more scalable and eliminate the need to solve for the field explicitly. They can be improved by adding empirically tuned fringing factors, determined by explicit calculations of the capacitance of the device.

The distance between the parallel plates can be determined using extrusion operators with the mesh search method set to “closest point” in the advanced settings. The operators will return the value of a given quantity at the closest point on the source surface, which is chosen to be the opposite plate of the capacitor. To ensure that the Jacobian of the operators is handled correctly, it is necessary to ensure that the dependent variables appear explicitly within the extrusion operators, which is why the coordinates of the moving surfaces are represented as $X+u$, and so on, in the expressions.

To understand the formulas added to implement the comb drive forces, consider the equation for the total force on any electrostatic actuator by using the equation

$$F = \frac{1}{2} \frac{\partial C}{\partial x} V^2 \quad (2)$$

where C is the comb capacitance and x is the coordinate along the direction of travel of the comb. For this example, assume that the comb travels parallel to the x -axis; more sophisticated expressions can be employed to capture effects due to comb misalignment. For motion along the x -axis with a displacement of u , the corresponding capacitance per unit height of a comb face is given by

$$C = C_0 + \frac{\epsilon_0 u}{d} \quad (3)$$

where C_0 is the comb capacitance at zero displacement. The force per unit length of each vertical edge at the tip of the comb is therefore

$$F_l = \frac{\epsilon_0 V^2}{2d} \quad (4)$$

As in the case of the parallel plate capacitors, the fidelity of the model can be improved by the calibration of fringing factors based on the accurate computation of the real capacitance of the structure.

Also note that several other techniques were used in the creation of the model. The signs of the forces are handled by assigning variables with different values to different edges or surfaces of the geometry. COMSOL's sophisticated perturbation machinery is used to automatically add AC forces to the model by means of the `linper()` operator. The model also uses a parameter `AC_on` to zero out the perturbation terms for stationary studies so that they do not appear in a misleading fashion in the postprocessing of stationary solutions.

To save time and file size, a relatively coarse mesh is used. Nevertheless, the mesh is parameterized to be ready for refinement studies. In the follow-up model, [Manufacturing Variation Effects in a Micromachined Comb-Drive Tuning Fork Rate Gyroscope](#), the Deformed Geometry feature will be used to study the effects of manufacturing variations,

with the advantage that it keeps the same mesh while varying the geometry, thus avoiding unwanted variations caused by a different mesh being used for a different geometry.

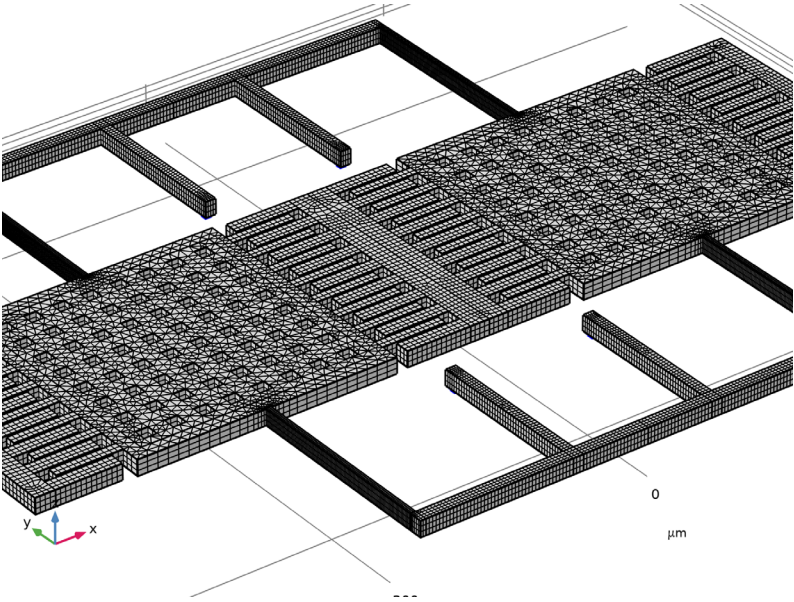

Figure 2: The mesh used in the model.

Results and Discussion

Figure 3 shows the stationary response of the device. The masses are pulled down slightly by the bias voltage of the sense electrodes. The masses do not move horizontally since the DC part of the comb drive forces for each mass are equal and in opposite directions so they cancel out.

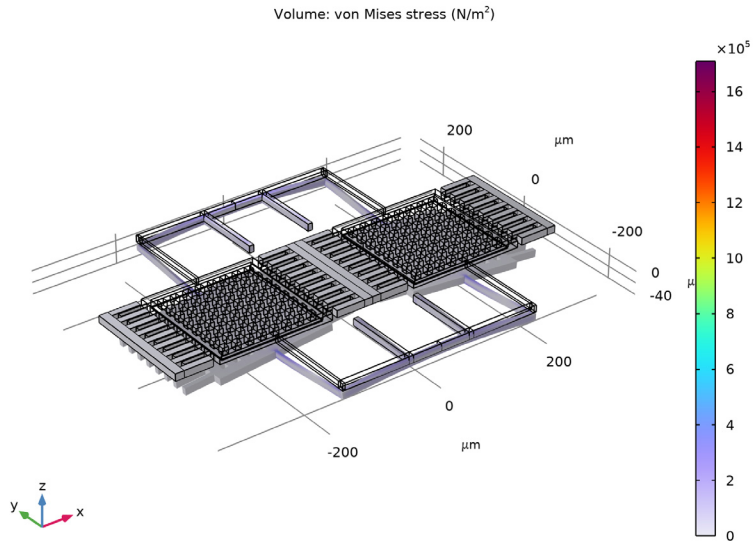

Figure 3: Stationary response of the device.

Figure 4 and Figure 5 show the eigenfrequencies and mode shapes of the in-plane drive mode and the out-of-plane sense mode, respectively.

Eigenfrequency= $38262+38.262i$ Hz Surface: Displacement magnitude (μm)

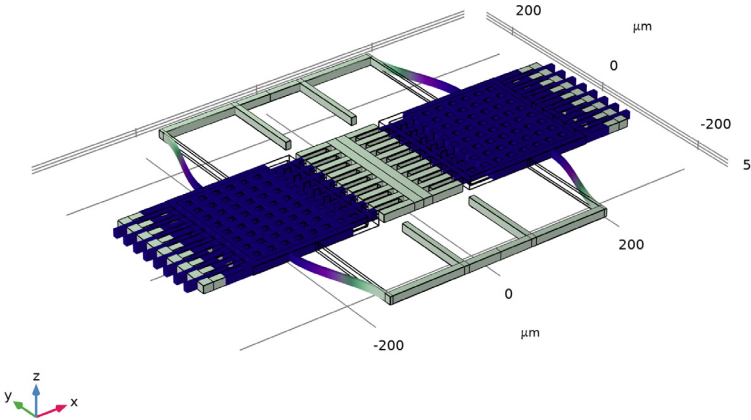

Figure 4: Drive mode shape.

Eigenfrequency= $41125+41.498i$ Hz Surface: Displacement magnitude (μm)

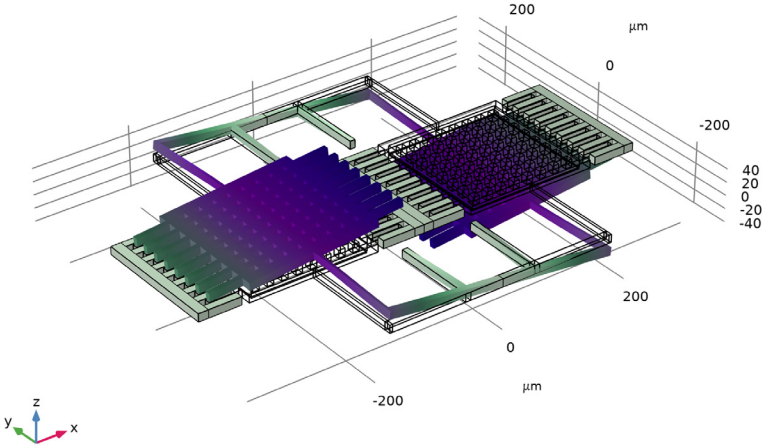

Figure 5: Sense mode shape.

The drive-mode and sense-mode resonant frequencies can be estimated with analytic formulas from standard textbooks (for example, Ref. 2). This can be done easily in a Parameters table in the model, as detailed in the [Modeling Instructions](#) section. The agreement between the numerical and analytic results is good; see [Table 1](#).

TABLE 1: NUMERICAL AND ANALYTIC RESULTS OF THE DRIVE-MODE AND SENSE-MODE FREQUENCIES.

	Drive mode	Sense mode
Numerical	38 kHz	41 kHz
Analytic	40 kHz	45 kHz

[Figure 6](#) shows the drive-mode displacement under the simulated operation. The amplitude can be read off from the color legend.

freq=38262 Hz, AC_on=1, Omega=100 deg/s Drive mode amplitude (μm)

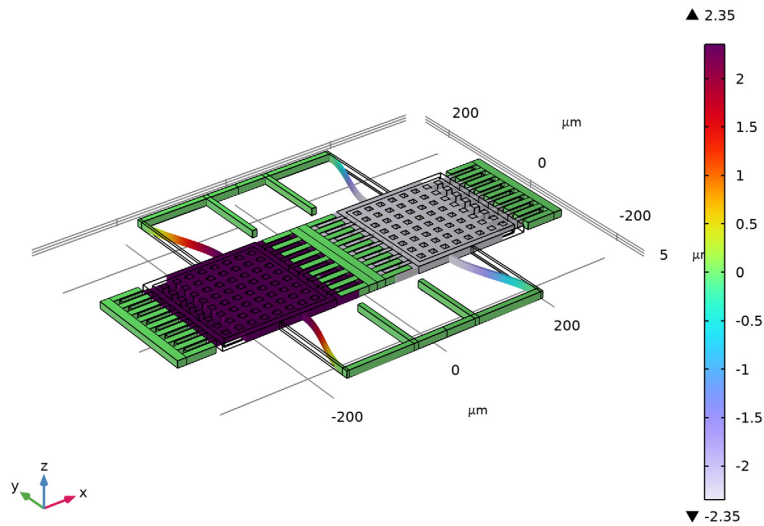

Figure 6: The drive mode displacement.

Figure 7 shows the sense-mode displacement. Due to the tilt of the masses, the amplitude is either read off the Evaluation 3D table after clicking around the centers of the masses, or evaluated using an average operator, as detailed in the [Modeling Instructions](#) section.

freq=38262 Hz, AC_on=1, Omega=100 deg/s Sense mode amplitude (μm)

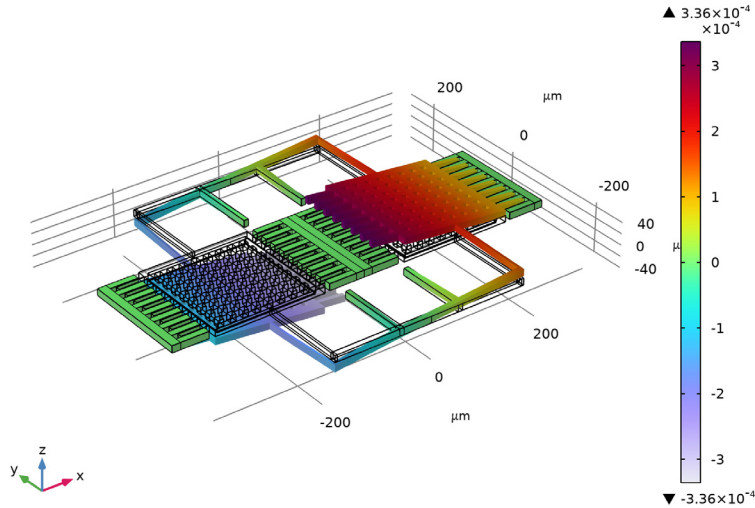

Figure 7: The sense-mode displacement.

The drive-mode and sense-mode amplitudes are also estimated with analytic formulas. The agreement between the numerical and analytic results is good; see [Table 2](#).

TABLE 2: NUMERICAL AND ANALYTIC RESULTS OF THE DRIVE-MODE AND SENSE-MODE AMPLITUDES.

	Drive mode	Sense mode
Numerical	2.4 μm	0.20 nm
Analytic	2.2 μm	0.21 nm

Finally, the sensitivity in terms of the sense capacitance change per rotation rate, in the units of $\text{aF}/(\text{deg}/\text{s})$, is computed using two alternative methods. Both give the same value of $0.23 \text{ aF}/(\text{deg}/\text{s})$. The capacitance amplitude at the rotation rate of $100 \text{ deg}/\text{s}$ is 23 aF .

Reference

I. J. Bernstein, S. Cho, A. T. King, A. Kourepenis, P. Maciel, and M. Weinberg, “A micromachined comb-drive tuning fork rate gyroscope,” Proceedings IEEE Micro Electro Mechanical Systems, Fort Lauderdale, FL, USA, 1993, pp. 143–148.

2. V. Kaajakari, *Practical MEMS*, Small Gear Pub. (Las Vegas, Nev.), 2009.

Application Library path: MEMS_Module/Sensors/
comb_drive_tuning_fork_gyroscope



Modeling Instructions

From the **File** menu, choose **New**.

NEW

In the **New** window, click  **Model Wizard**.

MODEL WIZARD

- 1 In the **Model Wizard** window, click  **3D**.
- 2 In the **Select Physics** tree, select **Structural Mechanics>Solid Mechanics (solid)**.
- 3 Click **Add**.
- 4 Click  **Study**.
- 5 In the **Select Study** tree, select **General Studies>Stationary**.
- 6 Click  **Done**.

GEOMETRY I

The Model Wizard starts the COMSOL Desktop at the **Geometry** node. Take the opportunity to set the length unit to microns for convenience.

- 1 In the **Model Builder** window, under **Component 1 (comp1)** click **Geometry 1**.
- 2 In the **Settings** window for **Geometry**, locate the **Units** section.
- 3 From the **Length unit** list, choose **µm**.

Enter model parameters in separate **Parameters** nodes according to the purposes of the parameters. First the ones for the geometry and mesh:

GLOBAL DEFINITIONS

Parameters 1 - Geometry & Mesh

- 1 In the **Model Builder** window, under **Global Definitions** click **Parameters 1**.

2 In the **Settings** window for **Parameters**, type Parameters 1 - Geometry & Mesh in the **Label** text field.

3 Locate the **Parameters** section. In the table, enter the following settings:

Name	Expression	Value	Description
l_mass	200[um]	2E-4 m	Mass length
w_mass	l_mass	2E-4 m	Mass width
y_spring_l	350[um]	3.5E-4 m	Y spring length
y_spring_w	10[um]	1E-5 m	Y spring width
etch_dim	10[um]	1E-5 m	Etch hole dimension
n_etch_x	8	8	Number of etch holes, x direction
n_etch_y	8	8	Number of etch holes, y direction
t_beam	12[um]	1.2E-5 m	Structure layer thickness
w_anchor	5[um]	5E-6 m	Anchor width
tether_x	55[um]	5.5E-5 m	Tether beam x-coordinate
x_spring_l	150[um]	1.5E-4 m	X spring length
x_spring_w	4[um]	4E-6 m	X spring width
tether_l	120[um]	1.2E-4 m	Tether beam length
tether_w	8[um]	8E-6 m	Tether beam width
w_stator_base	15[um]	1.5E-5 m	Stator base width
rotor_stator_overlap	40[um]	4E-5 m	Rotor/stator overlap length
l_rotor	50[um]	5E-5 m	Rotor comb length
w_rotor	8[um]	8E-6 m	Rotor comb width
n_combs	8	8	Number of combs
t_anchor	2[um]	2E-6 m	Anchor layer thickness
gap_combs	2[um]	2E-6 m	Gap between combs

Name	Expression	Value	Description
rotor_spacing	$(w_{\text{mass}} - w_{\text{rotor}} * n_{\text{combs}}) / (n_{\text{combs}} + 1)$	1.5111E-5 m	Spacing between rotor combs
w_stator	$\text{rotor_spacing} - 2 * \text{gap_combs}$	1.1111E-5 m	Stator comb width
electrode_ratio	0.9	0.9	Ratio for dimension of sense electrode
delta	0.01[um]	1E-8 m	Small distance for selections
mesh_factor	1	1	Mesh size factor (larger is bigger elements)

Then create a new **Parameters** node for the physics settings. Note the parameter AC_on will be used to control the on/off of the AC driving voltage.

Parameters 2 - Physics

- 1 In the **Home** toolbar, click **Pi Parameters** and choose **Add>Parameters**.
- 2 In the **Settings** window for **Parameters**, type Parameters 2 - Physics in the **Label** text field.
- 3 Locate the **Parameters** section. In the table, enter the following settings:

Name	Expression	Value	Description
Vbase	5[V]	5 V	Potential difference between mass and sense electrode
Vcomb	60[V]	60 V	Potential difference between comb rotors and stators
Q	500	500	Resonator quality factor
V_ac	3[V]	3 V	AC Comb voltage
Omega	0[deg/s]	0 rad/s	Angular rotation rate
AC_on	0	0	1 to turn on AC drive, 0 otherwise

Create the geometry. Note how various Selection features are used to label collections of geometric objects to make it easier to set up physics and mesh later. Note how Boolean and Transform operations can inherit the Cumulative selection of their input objects. First build the proof masses.

GEOMETRY I

Work Plane 1 - Mass

- 1 In the **Geometry** toolbar, click  **Work Plane**.
- 2 In the **Settings** window for **Work Plane**, type Work Plane 1 - Mass in the **Label** text field.

Work Plane 1 - Mass (wp1)>Plane Geometry

In the **Model Builder** window, click **Plane Geometry**.

Rectangle 1 - Mass: +X

- 1 In the **Work Plane** toolbar, click  **Rectangle**.
- 2 In the **Settings** window for **Rectangle**, type Rectangle 1 - Mass: +X in the **Label** text field.
- 3 Locate the **Size and Shape** section. In the **Width** text field, type l_{mass} .
- 4 In the **Height** text field, type w_{mass} .
- 5 Locate the **Position** section. From the **Base** list, choose **Center**.
- 6 In the **xw** text field, type $y_{spring1}/2$.
- 7 Locate the **Selections of Resulting Entities** section. Find the **Cumulative selection** subsection. Click **New**.
- 8 In the **New Cumulative Selection** dialog box, type Mass in the **Name** text field.
- 9 Click **OK**.
- 10 Right-click **Rectangle 1 - Mass: +X** and choose **Duplicate**.

Work Plane 1 - Mass (wp1)>Rectangle 1 - Mass: +X 1 (r2)

- 1 In the **Model Builder** window, under **Component 1 (comp1)>Geometry 1>Work Plane 1 - Mass (wp1)>Plane Geometry** click **Rectangle 1 - Mass: +X 1 (r2)**.
- 2 In the **Settings** window for **Rectangle**, type Rectangle 2 - Footprint of sense electrode in the **Label** text field.
- 3 Locate the **Size and Shape** section. In the **Width** text field, type $electrode_ratio * l_{mass}$.
- 4 In the **Height** text field, type $electrode_ratio * w_{mass}$.

Point 1 - For mesh copy

- 1 In the **Work Plane** toolbar, click  **Point**.
- 2 In the **Settings** window for **Point**, type Point 1 - For mesh copy in the **Label** text field.

- 3 Locate the **Point** section. In the **xw** text field, type $y_spring_1/2-electrode_ratio*1_mass/2$.
- 4 In the **yw** text field, type $electrode_ratio*w_mass/5$.
- 5 Locate the **Selections of Resulting Entities** section. Find the **Cumulative selection** subsection. From the **Contribute to** list, choose **Mass**.

Work Plane 1 - Mass (wp1)>Rectangle 3 (r3)

- 1 In the **Work Plane** toolbar, click  **Rectangle**.
- 2 In the **Settings** window for **Rectangle**, locate the **Size and Shape** section.
- 3 In the **Width** text field, type $etch_dim$.
- 4 In the **Height** text field, type $etch_dim$.
- 5 Locate the **Position** section. From the **Base** list, choose **Center**.
- 6 In the **xw** text field, type $y_spring_1/2+w_mass/2-w_mass/(n_etch_x+1)$.
- 7 In the **yw** text field, type $1_mass/2-1_mass/(n_etch_x+1)$.
- 8 Locate the **Selections of Resulting Entities** section. Find the **Cumulative selection** subsection. Click **New**.
- 9 In the **New Cumulative Selection** dialog box, type **Subtract** in the **Name** text field.
- 10 Click **OK**.

Work Plane 1 - Mass (wp1)>Array 1 (arr1)

- 1 In the **Work Plane** toolbar, click  **Transforms** and choose **Array**.
- 2 In the **Settings** window for **Array**, locate the **Input** section.
- 3 From the **Input objects** list, choose **Subtract**.
- 4 Locate the **Size** section. In the **xw size** text field, type n_etch_x .
- 5 In the **yw size** text field, type n_etch_y .
- 6 Locate the **Displacement** section. In the **xw** text field, type $-w_mass/(n_etch_x+1)$.
- 7 In the **yw** text field, type $-1_mass/(n_etch_x+1)$.

Work Plane 1 - Mass (wp1)>Difference 1 (dif1)

- 1 In the **Work Plane** toolbar, click  **Booleans and Partitions** and choose **Difference**.
- 2 In the **Settings** window for **Difference**, locate the **Difference** section.
- 3 From the **Objects to add** list, choose **Mass**.
- 4 From the **Objects to subtract** list, choose **Subtract**.

Work Plane 1 - Mass (wp1)>Mirror 1 (mir1)

- 1 In the **Work Plane** toolbar, click  **Transforms** and choose **Mirror**.

- 2 In the **Settings** window for **Mirror**, locate the **Input** section.
- 3 From the **Input objects** list, choose **Mass**.
- 4 Select the **Keep input objects** check box.

Extrude 1 - Mass

- 1 In the **Model Builder** window, right-click **Geometry 1** and choose **Extrude**.
- 2 In the **Settings** window for **Extrude**, type Extrude 1 - Mass in the **Label** text field.
- 3 Locate the **Distances** section. In the table, enter the following settings:

Distances (µm)
t_beam

- 4 Locate the **Selections of Resulting Entities** section. Select the **Resulting objects selection** check box.
- 5 From the **Show in physics** list, choose **All levels**.
- 6 Click  **Build Selected**.

Then build the anchors.

Work Plane 2 - Anchors

- 1 In the **Geometry** toolbar, click  **Work Plane**.
- 2 In the **Settings** window for **Work Plane**, type Work Plane 2 - Anchors in the **Label** text field.

Work Plane 2 - Anchors (wp2)>Plane Geometry

In the **Model Builder** window, click **Plane Geometry**.

Rectangle 1 - Spring Anchor

- 1 In the **Work Plane** toolbar, click  **Rectangle**.
- 2 In the **Settings** window for **Rectangle**, type Rectangle 1 - Spring Anchor in the **Label** text field.
- 3 Locate the **Size and Shape** section. In the **Width** text field, type w_anchor.
- 4 In the **Height** text field, type w_anchor.
- 5 Locate the **Position** section. From the **Base** list, choose **Center**.
- 6 In the **xw** text field, type tether_x.
- 7 In the **yw** text field, type $1_mass/2+x_spring_1+y_spring_w/2-y_spring_w/2-tether_1+w_anchor$.

- 8 Locate the **Selections of Resulting Entities** section. Find the **Cumulative selection** subsection. Click **New**.
- 9 In the **New Cumulative Selection** dialog box, type Anchors in the **Name** text field.
- 10 Click **OK**.
- 11 Right-click **Rectangle 1 - Spring Anchor** and choose **Duplicate**.

Work Plane 2 - Anchors (wp2)>Rectangle 1 - Spring Anchor 1 (r2)

- 1 In the **Model Builder** window, under **Component 1 (comp1)>Geometry 1>Work Plane 2 - Anchors (wp2)>Plane Geometry** click **Rectangle 1 - Spring Anchor 1 (r2)**.
- 2 In the **Settings** window for **Rectangle**, type Rectangle 2 - Stator Anchor in the **Label** text field.
- 3 Locate the **Position** section. In the **xw** text field, type $y_spring_1/2+w_mass/2+w_stator_base/2+2*1_rotor-rotor_stator_overlap$.
- 4 In the **yw** text field, type $1_mass/2-0.5*1_mass/(n_combs+1)$.

Work Plane 2 - Anchors (wp2)>Mirror 1 (mir1)

- 1 In the **Work Plane** toolbar, click  **Transforms** and choose **Mirror**.
- 2 In the **Settings** window for **Mirror**, locate the **Input** section.
- 3 From the **Input objects** list, choose **Anchors**.
- 4 Select the **Keep input objects** check box.

Work Plane 2 - Anchors (wp2)>Rectangle 2 - Stator Anchor (r2)

In the **Model Builder** window, right-click **Rectangle 2 - Stator Anchor (r2)** and choose **Duplicate**.

Work Plane 2 - Anchors (wp2)>Rectangle 2 - Stator Anchor 1 (r3)

- 1 In the **Model Builder** window, under **Component 1 (comp1)>Geometry 1>Work Plane 2 - Anchors (wp2)>Plane Geometry** click **Rectangle 2 - Stator Anchor 1 (r3)**.
- 2 In the **Settings** window for **Rectangle**, type Rectangle 3 - Stator Anchor 2 in the **Label** text field.
- 3 Locate the **Position** section. In the **xw** text field, type 0.

Work Plane 2 - Anchors (wp2)>Mirror 2 (mir2)

- 1 In the **Work Plane** toolbar, click  **Transforms** and choose **Mirror**.
- 2 In the **Settings** window for **Mirror**, locate the **Input** section.
- 3 From the **Input objects** list, choose **Anchors**.
- 4 Select the **Keep input objects** check box.

- 5 Locate the **Normal Vector to Line of Reflection** section. In the **xw** text field, type 0.
- 6 In the **yw** text field, type 1.

Extrude 2 - Anchors

- 1 In the **Model Builder** window, right-click **Geometry 1** and choose **Extrude**.
- 2 In the **Settings** window for **Extrude**, type Extrude 2 - Anchors in the **Label** text field.
- 3 Locate the **Distances** section. In the table, enter the following settings:

Distances (μm)
t_anchor

- 4 Select the **Reverse direction** check box.
- 5 Locate the **Selections of Resulting Entities** section. Select the **Resulting objects selection** check box.
- 6 From the **Show in physics** list, choose **All levels**.
- 7 Click  **Build Selected**.

Next build the springs.

Work Plane 3 - Springs

- 1 In the **Geometry** toolbar, click  **Work Plane**.
- 2 In the **Settings** window for **Work Plane**, type Work Plane 3 - Springs in the **Label** text field.

Work Plane 3 - Springs (wp3)>Plane Geometry

In the **Model Builder** window, click **Plane Geometry**.

Rectangle 1 - Y Spring: +Y

- 1 In the **Work Plane** toolbar, click  **Rectangle**.
- 2 In the **Settings** window for **Rectangle**, type Rectangle 1 - Y Spring: +Y in the **Label** text field.
- 3 Locate the **Size and Shape** section. In the **Width** text field, type $y_spring_1 + x_spring_w$.
- 4 In the **Height** text field, type y_spring_w .
- 5 Locate the **Position** section. From the **Base** list, choose **Center**.
- 6 In the **yw** text field, type $1_mass/2 + x_spring_1 + y_spring_w/2$.
- 7 Locate the **Selections of Resulting Entities** section. Find the **Cumulative selection** subsection. Click **New**.

- 8 In the **New Cumulative Selection** dialog box, type Mirror Y in the **Name** text field.
- 9 Click **OK**.

Rectangle 2 - X Spring: +X +Y

- 1 In the **Work Plane** toolbar, click  **Rectangle**.
- 2 In the **Settings** window for **Rectangle**, type Rectangle 2 - X Spring: +X +Y in the **Label** text field.
- 3 Locate the **Size and Shape** section. In the **Width** text field, type x_spring_w .
- 4 In the **Height** text field, type $x_spring_l+y_spring_w$.
- 5 Locate the **Position** section. From the **Base** list, choose **Center**.
- 6 In the **xw** text field, type $y_spring_l/2$.
- 7 In the **yw** text field, type $l_mass/2+x_spring_l/2+y_spring_w/2$.
- 8 Locate the **Selections of Resulting Entities** section. Find the **Cumulative selection** subsection. Click **New**.
- 9 In the **New Cumulative Selection** dialog box, type Mirror XY in the **Name** text field.
- 10 Click **OK**.

Rectangle 3 - Tether: +X +Y

- 1 In the **Work Plane** toolbar, click  **Rectangle**.
- 2 In the **Settings** window for **Rectangle**, type Rectangle 3 - Tether: +X +Y in the **Label** text field.
- 3 Locate the **Size and Shape** section. In the **Width** text field, type $tether_w$.
- 4 In the **Height** text field, type $tether_l+y_spring_w$.
- 5 Locate the **Position** section. In the **xw** text field, type $tether_x-tether_w/2$.
- 6 In the **yw** text field, type $l_mass/2+x_spring_l+y_spring_w/2-y_spring_w/2-tether_l$.
- 7 Locate the **Selections of Resulting Entities** section. Find the **Cumulative selection** subsection. From the **Contribute to** list, choose **Mirror XY**.

Work Plane 3 - Springs (wp3)>Mirror 1 (mir1)

- 1 In the **Work Plane** toolbar, click  **Transforms** and choose **Mirror**.
- 2 In the **Settings** window for **Mirror**, locate the **Input** section.
- 3 From the **Input objects** list, choose **Mirror XY**.
- 4 Select the **Keep input objects** check box.
- 5 Locate the **Normal Vector to Line of Reflection** section. In the **xw** text field, type 0.

6 In the **yw** text field, type 1.

Work Plane 3 - Springs (wp3)>Mirror 2 (mir2)

1 In the **Work Plane** toolbar, click  **Transforms** and choose **Mirror**.

2 In the **Settings** window for **Mirror**, locate the **Input** section.

3 From the **Input objects** list, choose **Mirror XY**.

4 Select the **Keep input objects** check box.

Work Plane 3 - Springs (wp3)>Mirror 3 (mir3)

1 In the **Work Plane** toolbar, click  **Transforms** and choose **Mirror**.

2 In the **Settings** window for **Mirror**, locate the **Input** section.

3 From the **Input objects** list, choose **Mirror Y**.

4 Locate the **Normal Vector to Line of Reflection** section. In the **xw** text field, type 0.

5 In the **yw** text field, type 1.

6 Locate the **Input** section. Select the **Keep input objects** check box.

Extrude 3 - Springs

1 In the **Model Builder** window, right-click **Geometry 1** and choose **Extrude**.

2 In the **Settings** window for **Extrude**, type Extrude 3 - Springs in the **Label** text field.

3 Locate the **Distances** section. In the table, enter the following settings:

Distances (μm)

t_beam

4 Locate the **Selections of Resulting Entities** section. Select the **Resulting objects selection** check box.

5 From the **Show in physics** list, choose **All levels**.

6 Click  **Build Selected**.

Then build the rotor combs.

Work Plane 4 - Rotors

1 In the **Geometry** toolbar, click  **Work Plane**.

2 In the **Settings** window for **Work Plane**, type Work Plane 4 - Rotors in the **Label** text field.

Work Plane 4 - Rotors (wp4)>Plane Geometry

In the **Model Builder** window, click **Plane Geometry**.

Rectangle 1 - 1st Comb

- 1 In the **Work Plane** toolbar, click  **Rectangle**.
- 2 In the **Settings** window for **Rectangle**, type Rectangle 1 - 1st Comb in the **Label** text field.
- 3 Locate the **Size and Shape** section. In the **Width** text field, type l_{rotor} .
- 4 In the **Height** text field, type w_{rotor} .
- 5 Locate the **Position** section. From the **Base** list, choose **Center**.
- 6 In the **xw** text field, type $y_{\text{spring}}/2 + w_{\text{mass}}/2 + l_{\text{rotor}}/2$.
- 7 In the **yw** text field, type $w_{\text{mass}}/2 - \text{rotor_spacing} - w_{\text{rotor}}/2$.
- 8 Locate the **Selections of Resulting Entities** section. Find the **Cumulative selection** subsection. Click **New**.
- 9 In the **New Cumulative Selection** dialog box, type Rotors in the **Name** text field.
- 10 Click **OK**.

Work Plane 4 - Rotors (wp4)>Array 1 (arr1)

- 1 In the **Work Plane** toolbar, click  **Transforms** and choose **Array**.
- 2 In the **Settings** window for **Array**, locate the **Input** section.
- 3 From the **Input objects** list, choose **Rotors**.
- 4 Locate the **Size** section. From the **Array type** list, choose **Linear**.
- 5 In the **Size** text field, type n_{combs} .
- 6 Locate the **Displacement** section. In the **yw** text field, type $-(\text{rotor_spacing} + w_{\text{rotor}})$.

Work Plane 4 - Rotors (wp4)>Mirror 1 (mir1)

- 1 In the **Work Plane** toolbar, click  **Transforms** and choose **Mirror**.
- 2 In the **Settings** window for **Mirror**, locate the **Input** section.
- 3 From the **Input objects** list, choose **Rotors**.
- 4 Select the **Keep input objects** check box.
- 5 Locate the **Point on Line of Reflection** section. In the **xw** text field, type $y_{\text{spring}}/2$.

Work Plane 4 - Rotors (wp4)>Mirror 2 (mir2)

- 1 In the **Work Plane** toolbar, click  **Transforms** and choose **Mirror**.
- 2 In the **Settings** window for **Mirror**, locate the **Input** section.
- 3 From the **Input objects** list, choose **Rotors**.
- 4 Select the **Keep input objects** check box.

Extrude 4 - Rotors

- 1 In the **Model Builder** window, right-click **Geometry 1** and choose **Extrude**.
- 2 In the **Settings** window for **Extrude**, type Extrude 4 - Rotors in the **Label** text field.
- 3 Locate the **Distances** section. In the table, enter the following settings:

Distances (μm)
t_beam

- 4 Locate the **Selections of Resulting Entities** section. Select the **Resulting objects selection** check box.
- 5 From the **Show in physics** list, choose **All levels**.
- 6 Click  **Build Selected**.

Next build the stator combs.

Work Plane 5 - Stators

- 1 In the **Geometry** toolbar, click  **Work Plane**.
- 2 In the **Settings** window for **Work Plane**, type Work Plane 5 - Stators in the **Label** text field.

Work Plane 5 - Stators (wp5)>Plane Geometry

In the **Model Builder** window, click **Plane Geometry**.

Rectangle 1 - 1st Comb

- 1 In the **Work Plane** toolbar, click  **Rectangle**.
- 2 In the **Settings** window for **Rectangle**, type Rectangle 1 - 1st Comb in the **Label** text field.
- 3 Locate the **Size and Shape** section. In the **Width** text field, type 1_rotor.
- 4 In the **Height** text field, type w_stator.
- 5 Locate the **Position** section. From the **Base** list, choose **Center**.
- 6 In the **xw** text field, type $y_{\text{spring}_1}/2+w_{\text{mass}}/2+1_{\text{rotor}}/2+1_{\text{rotor-rotor_stator_overlap}}$.
- 7 In the **yw** text field, type $w_{\text{mass}}/2-0.5*\text{rotor_spacing}$.
- 8 Locate the **Selections of Resulting Entities** section. Find the **Cumulative selection** subsection. Click **New**.
- 9 In the **New Cumulative Selection** dialog box, type Stators in the **Name** text field.
- 10 Click **OK**.

Work Plane 5 - Stators (wp5)>Array 1 (arr1)

- 1 In the **Work Plane** toolbar, click  **Transforms** and choose **Array**.
- 2 In the **Settings** window for **Array**, locate the **Input** section.
- 3 From the **Input objects** list, choose **Stators**.
- 4 Locate the **Size** section. From the **Array type** list, choose **Linear**.
- 5 In the **Size** text field, type $n_combs+1$.
- 6 Locate the **Displacement** section. In the **yw** text field, type $-(rotor_spacing+w_rotor)$.

Rectangle 2 - Stator Base

- 1 In the **Work Plane** toolbar, click  **Rectangle**.
- 2 In the **Settings** window for **Rectangle**, type Rectangle 2 - Stator Base in the **Label** text field.
- 3 Locate the **Size and Shape** section. In the **Width** text field, type w_stator_base .
- 4 In the **Height** text field, type $w_mass-rotor_spacing+w_stator$.
- 5 Locate the **Position** section. From the **Base** list, choose **Center**.
- 6 In the **xw** text field, type $y_spring_1/2+w_mass/2+w_stator_base/2+2*1_rotor-rotor_stator_overlap$.
- 7 Locate the **Selections of Resulting Entities** section. Find the **Cumulative selection** subsection. Click **New**.
- 8 In the **New Cumulative Selection** dialog box, type Stator Base in the **Name** text field.
- 9 Click **OK**.

Work Plane 5 - Stators (wp5)>Mirror 1 (mir1)

- 1 In the **Work Plane** toolbar, click  **Transforms** and choose **Mirror**.
- 2 In the **Settings** window for **Mirror**, locate the **Input** section.
- 3 From the **Input objects** list, choose **Stators**.
- 4 Select the **Keep input objects** check box.
- 5 Locate the **Point on Line of Reflection** section. In the **xw** text field, type $y_spring_1/2$.

Work Plane 5 - Stators (wp5)>Mirror 2 (mir2)

- 1 In the **Work Plane** toolbar, click  **Transforms** and choose **Mirror**.
- 2 In the **Settings** window for **Mirror**, locate the **Input** section.
- 3 From the **Input objects** list, choose **Stators**.
- 4 Select the **Keep input objects** check box.

Work Plane 5 - Stators (wp5)>Mirror 3 (mir3)

- 1 In the **Work Plane** toolbar, click  **Transforms** and choose **Mirror**.
- 2 In the **Settings** window for **Mirror**, locate the **Input** section.
- 3 From the **Input objects** list, choose **Stator Base**.
- 4 Select the **Keep input objects** check box.

Rectangle 3 - Stator Base

- 1 In the **Work Plane** toolbar, click  **Rectangle**.
- 2 In the **Settings** window for **Rectangle**, type Rectangle 3 - Stator Base in the **Label** text field.
- 3 Locate the **Size and Shape** section. In the **Width** text field, type $2*(y_spring_1/2 - 1_mass/2 - 1_rotor - (1_rotor - rotor_stator_overlap))$.
- 4 In the **Height** text field, type $w_mass - rotor_spacing + w_stator$.
- 5 Locate the **Position** section. From the **Base** list, choose **Center**.
- 6 Locate the **Selections of Resulting Entities** section. Find the **Cumulative selection** subsection. From the **Contribute to** list, choose **Stator Base**.

Extrude 5 - Stators

- 1 In the **Model Builder** window, right-click **Geometry 1** and choose **Extrude**.
- 2 In the **Settings** window for **Extrude**, type Extrude 5 - Stators in the **Label** text field.
- 3 Locate the **Distances** section. In the table, enter the following settings:

Distances (μm)
t_beam

- 4 Locate the **Selections of Resulting Entities** section. Select the **Resulting objects selection** check box.
- 5 From the **Show in physics** list, choose **All levels**.
- 6 Click  **Build Selected**.

Then build the sense electrodes.

Work Plane 6 - Sense Electrodes

- 1 In the **Geometry** toolbar, click  **Work Plane**.
- 2 In the **Settings** window for **Work Plane**, type Work Plane 6 - Sense Electrodes in the **Label** text field.
- 3 Locate the **Plane Definition** section. In the **z-coordinate** text field, type -t_anchor.

- 4 Locate the **Selections of Resulting Entities** section. Select the **Resulting objects selection** check box.

Work Plane 6 - Sense Electrodes (wp6)>Plane Geometry

In the **Model Builder** window, click **Plane Geometry**.

Rectangle 1 - Sense electrode

- 1 In the **Work Plane** toolbar, click  **Rectangle**.
- 2 In the **Settings** window for **Rectangle**, type Rectangle 1 - Sense electrode in the **Label** text field.
- 3 Locate the **Size and Shape** section. In the **Width** text field, type $\text{electrode_ratio} * 1_mass$.
- 4 In the **Height** text field, type $\text{electrode_ratio} * w_mass$.
- 5 Locate the **Position** section. From the **Base** list, choose **Center**.
- 6 In the **xw** text field, type $y_spring_1/2$.
- 7 Locate the **Selections of Resulting Entities** section. Find the **Cumulative selection** subsection. Click **New**.
- 8 In the **New Cumulative Selection** dialog box, type Sense electrode in the **Name** text field.
- 9 Click **OK**.

Point 1 - For mesh copy

- 1 In the **Work Plane** toolbar, click  **Point**.
- 2 In the **Settings** window for **Point**, type Point 1 - For mesh copy in the **Label** text field.
- 3 Locate the **Point** section. In the **xw** text field, type $y_spring_1/2 - \text{electrode_ratio} * 1_mass/2$.
- 4 In the **yw** text field, type $\text{electrode_ratio} * w_mass/5$.
- 5 Locate the **Selections of Resulting Entities** section. Find the **Cumulative selection** subsection. From the **Contribute to** list, choose **Sense electrode**.

Work Plane 6 - Sense Electrodes (wp6)>Mirror 1 (mir1)

- 1 In the **Work Plane** toolbar, click  **Transforms** and choose **Mirror**.
- 2 In the **Settings** window for **Mirror**, locate the **Input** section.
- 3 From the **Input objects** list, choose **Sense electrode**.
- 4 Select the **Keep input objects** check box.

Finally build the symmetry plane for meshing.

Work Plane 7 - Symmetry Plane

- 1 In the **Model Builder** window, right-click **Geometry 1** and choose **Work Plane**.
- 2 In the **Settings** window for **Work Plane**, type Work Plane 7 - Symmetry Plane in the **Label** text field.
- 3 Locate the **Plane Definition** section. From the **Plane** list, choose **yz-plane**.

Work Plane 7 - Symmetry Plane (wp7)>Plane Geometry

In the **Model Builder** window, click **Plane Geometry**.

Work Plane 7 - Symmetry Plane (wp7)>Cross Section 1 (cro1)

- 1 In the **Work Plane** toolbar, click  **Cross Section**.
- 2 In the **Settings** window for **Cross Section**, locate the **Selections of Resulting Entities** section.
- 3 Find the **Cumulative selection** subsection. Click **New**.
- 4 In the **New Cumulative Selection** dialog box, type Symmetry Plane in the **Name** text field.
- 5 Click **OK**.

Form Union (fin)

- 1 In the **Home** toolbar, click  **Build All**.

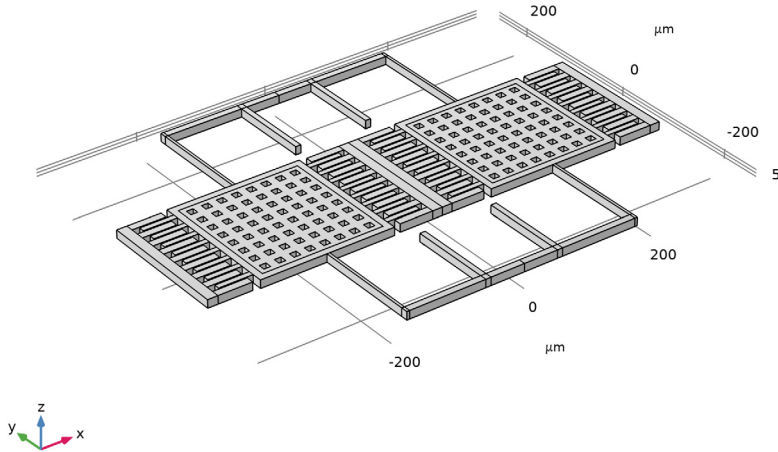

- 2 In the **Model Builder** window, under **Component 1 (comp1)>Geometry 1** click **Form Union (fin)**.



Now create additional selections to make it easy to set up the physics and mesh. Turn on wireframe rendering to see the selection more easily.

DEFINITIONS

Box 1 - Bottom of Beam

- 1 In the **Definitions** toolbar, click  **Box**.
- 2 In the **Settings** window for **Box**, type Box 1 - Bottom of Beam in the **Label** text field.
- 3 Locate the **Geometric Entity Level** section. From the **Level** list, choose **Boundary**.
- 4 Locate the **Box Limits** section. In the **z minimum** text field, type $-\text{delta}$.
- 5 In the **z maximum** text field, type delta .
- 6 Locate the **Output Entities** section. From the **Include entity if** list, choose **Entity inside box**.
- 7 Click the  **Wireframe Rendering** button in the **Graphics** toolbar.

Box 2 - Entire Beam Layer

- 1 In the **Definitions** toolbar, click  **Box**.

- 2 In the **Settings** window for **Box**, type Box 2 - Entire Beam Layer in the **Label** text field.
- 3 Locate the **Box Limits** section. In the **z minimum** text field, type $t_{\text{beam}}/2-\text{delta}$.
- 4 In the **z maximum** text field, type $t_{\text{beam}}/2+\text{delta}$.

Box 1 - Bottom of Beam

In the **Model Builder** window, right-click **Box 1 - Bottom of Beam** and choose **Duplicate**.

Box 3 - Anchor base

- 1 In the **Model Builder** window, under **Component 1 (comp1)>Definitions>Selections** click **Box 1 - Bottom of Beam 1**.
- 2 In the **Settings** window for **Box**, type Box 3 - Anchor base in the **Label** text field.
- 3 Locate the **Box Limits** section. In the **z minimum** text field, type $-t_{\text{anchor}}-\text{delta}$.
- 4 In the **z maximum** text field, type $-t_{\text{anchor}}+\text{delta}$.

Intersection 1 - Lower Electrode

- 1 In the **Definitions** toolbar, click  **Intersection**.
- 2 In the **Settings** window for **Intersection**, type Intersection 1 - Lower Electrode in the **Label** text field.
- 3 Locate the **Geometric Entity Level** section. From the **Level** list, choose **Boundary**.
- 4 Locate the **Input Entities** section. Under **Selections to intersect**, click **+ Add**.
- 5 In the **Add** dialog box, select **Box 1 - Bottom of Beam** in the **Selections to intersect** list.
- 6 Click **OK**.
- 7 In the **Settings** window for **Intersection**, locate the **Input Entities** section.
- 8 Under **Selections to intersect**, click **+ Add**.
- 9 In the **Add** dialog box, select **Extrude 1 - Mass** in the **Selections to intersect** list.
- 10 Click **OK**.

Create selections for the vertical walls of the comb drives.

Box 4 - Comb vertical walls 1

- 1 In the **Definitions** toolbar, click  **Box**.
- 2 In the **Settings** window for **Box**, type Box 4 - Comb vertical walls 1 in the **Label** text field.
- 3 Locate the **Geometric Entity Level** section. From the **Level** list, choose **Boundary**.
- 4 Locate the **Box Limits** section. In the **x minimum** text field, type $y_{\text{spring}_1}/2+w_{\text{mass}}/2+l_{\text{rotor}}/2-\text{delta}$.

- 5 In the **x maximum** text field, type $y_spring_1/2+w_mass/2+l_rotor/2+\delta$.
- 6 In the **y minimum** text field, type $-w_mass/2+\delta$.
- 7 In the **y maximum** text field, type $w_mass/2-\delta$.
- 8 In the **z minimum** text field, type $t_beam/2$.
- 9 In the **z maximum** text field, type $t_beam/2+\delta$.
- 10 Right-click **Box 4 - Comb vertical walls 1** and choose **Duplicate**.

Box 5 - Comb vertical walls 2

- 1 In the **Model Builder** window, under **Component 1 (comp1)>Definitions>Selections** click **Box 4 - Comb vertical walls 1.1**.
- 2 In the **Settings** window for **Box**, type Box 5 - Comb vertical walls 2 in the **Label** text field.
- 3 Locate the **Box Limits** section. In the **x minimum** text field, type $-(y_spring_1/2+w_mass/2+l_rotor/2)-\delta$.
- 4 In the **x maximum** text field, type $-(y_spring_1/2+w_mass/2+l_rotor/2)+\delta$.

Box 4 - Comb vertical walls 1

In the **Model Builder** window, right-click **Box 4 - Comb vertical walls 1** and choose **Duplicate**.

Box 6 - Comb vertical walls 3

- 1 In the **Model Builder** window, under **Component 1 (comp1)>Definitions>Selections** click **Box 4 - Comb vertical walls 1.1**.
- 2 In the **Settings** window for **Box**, type Box 6 - Comb vertical walls 3 in the **Label** text field.
- 3 Locate the **Box Limits** section. In the **x minimum** text field, type $y_spring_1/2-w_mass/2-l_rotor/2-\delta$.
- 4 In the **x maximum** text field, type $y_spring_1/2-w_mass/2-l_rotor/2+\delta$.

Box 5 - Comb vertical walls 2

In the **Model Builder** window, right-click **Box 5 - Comb vertical walls 2** and choose **Duplicate**.

Box 7 - Comb vertical walls 4

- 1 In the **Model Builder** window, under **Component 1 (comp1)>Definitions>Selections** click **Box 5 - Comb vertical walls 2.1**.
- 2 In the **Settings** window for **Box**, type Box 7 - Comb vertical walls 4 in the **Label** text field.
- 3 Locate the **Box Limits** section. In the **x minimum** text field, type $-(y_spring_1/2-w_mass/2-l_rotor/2)-\delta$.

4 In the **x maximum** text field, type $-(y_spring_1/2-w_mass/2-l_rotor/2)+\delta$.

Union 1 - Comb Vertical Walls

- 1 In the **Definitions** toolbar, click  **Union**.
- 2 In the **Settings** window for **Union**, type Union 1 - Comb Vertical Walls in the **Label** text field.
- 3 Locate the **Geometric Entity Level** section. From the **Level** list, choose **Boundary**.
- 4 Locate the **Input Entities** section. Under **Selections to add**, click **+ Add**.
- 5 In the **Add** dialog box, in the **Selections to add** list, choose **Box 4 - Comb vertical walls 1**, **Box 5 - Comb vertical walls 2**, **Box 6 - Comb vertical walls 3**, and **Box 7 - Comb vertical walls 4**.
- 6 Click **OK**.

Intersection 2 - Stator Vertical Walls

- 1 In the **Definitions** toolbar, click  **Intersection**.
- 2 In the **Settings** window for **Intersection**, type Intersection 2 - Stator Vertical Walls in the **Label** text field.
- 3 Locate the **Geometric Entity Level** section. From the **Level** list, choose **Boundary**.
- 4 Locate the **Input Entities** section. Under **Selections to intersect**, click **+ Add**.
- 5 In the **Add** dialog box, in the **Selections to intersect** list, choose **Union 1 - Comb Vertical Walls** and **Extrude 5 - Stators**.
- 6 Click **OK**.

Create selections for the end edges of the comb drives.

Box 4 - Comb vertical walls 1

In the **Model Builder** window, right-click **Box 4 - Comb vertical walls 1** and choose **Duplicate**.

Box 8 - Rotor tip edge 1

- 1 In the **Model Builder** window, under **Component 1 (comp1)>Definitions>Selections** click **Box 4 - Comb vertical walls 1.1**.
- 2 In the **Settings** window for **Box**, type Box 8 - Rotor tip edge 1 in the **Label** text field.
- 3 Locate the **Geometric Entity Level** section. From the **Level** list, choose **Edge**.
- 4 Locate the **Box Limits** section. In the **x minimum** text field, type $y_spring_1/2+w_mass/2+l_rotor-\delta$.
- 5 In the **x maximum** text field, type $y_spring_1/2+w_mass/2+l_rotor+\delta$.
- 6 Right-click **Box 8 - Rotor tip edge 1** and choose **Duplicate**.

Box 9 - Rotor tip edge 2

- 1 In the **Model Builder** window, under **Component 1 (comp1)>Definitions>Selections** click **Box 8 - Rotor tip edge 1.1**.
- 2 In the **Settings** window for **Box**, type **Box 9 - Rotor tip edge 2** in the **Label** text field.
- 3 Locate the **Box Limits** section. In the **x minimum** text field, type $-(y_spring_1/2 + w_mass/2 + l_rotor) - \delta$.
- 4 In the **x maximum** text field, type $-(y_spring_1/2 + w_mass/2 + l_rotor) + \delta$.

Box 8 - Rotor tip edge 1

In the **Model Builder** window, right-click **Box 8 - Rotor tip edge 1** and choose **Duplicate**.

Box 10 - Rotor tip edge 3

- 1 In the **Model Builder** window, under **Component 1 (comp1)>Definitions>Selections** click **Box 8 - Rotor tip edge 1.1**.
- 2 In the **Settings** window for **Box**, type **Box 10 - Rotor tip edge 3** in the **Label** text field.
- 3 Locate the **Box Limits** section. In the **x minimum** text field, type $y_spring_1/2 - w_mass/2 - l_rotor - \delta$.
- 4 In the **x maximum** text field, type $y_spring_1/2 - w_mass/2 - l_rotor + \delta$.



Box 9 - Rotor tip edge 2

In the **Model Builder** window, right-click **Box 9 - Rotor tip edge 2** and choose **Duplicate**.

Box 11 - Rotor tip edge 4

- 1 In the **Model Builder** window, under **Component 1 (comp1)>Definitions>Selections** click **Box 9 - Rotor tip edge 2.1**.
- 2 In the **Settings** window for **Box**, type **Box 11 - Rotor tip edge 4** in the **Label** text field.
- 3 Locate the **Box Limits** section. In the **x minimum** text field, type $-(y_spring_1/2 - w_mass/2 - l_rotor) - \delta$.
- 4 In the **x maximum** text field, type $-(y_spring_1/2 - w_mass/2 - l_rotor) + \delta$.

Union 2 - Rotor Tip Edges +X DC

- 1 In the **Definitions** toolbar, click  **Union**.
- 2 In the **Settings** window for **Union**, type **Union 2 - Rotor Tip Edges +X DC** in the **Label** text field.
- 3 Locate the **Geometric Entity Level** section. From the **Level** list, choose **Edge**.
- 4 Locate the **Input Entities** section. Under **Selections to add**, click  **Add**.

5 In the **Add** dialog box, in the **Selections to add** list, choose **Box 8 - Rotor tip edge 1** and **Box 11 - Rotor tip edge 4**.

6 Click **OK**.

Union 3 - Rotor Tip Edges -X DC

1 In the **Definitions** toolbar, click  **Union**.

2 In the **Settings** window for **Union**, type Union 3 - Rotor Tip Edges -X DC in the **Label** text field.

3 Locate the **Geometric Entity Level** section. From the **Level** list, choose **Edge**.

4 Locate the **Input Entities** section. Under **Selections to add**, click **+ Add**.

5 In the **Add** dialog box, in the **Selections to add** list, choose **Box 9 - Rotor tip edge 2** and **Box 10 - Rotor tip edge 3**.

6 Click **OK**.

Union 4 - Rotor Tip Edges +X AC

1 In the **Definitions** toolbar, click  **Union**.

2 In the **Settings** window for **Union**, type Union 4 - Rotor Tip Edges +X AC in the **Label** text field.

3 Locate the **Geometric Entity Level** section. From the **Level** list, choose **Edge**.

4 Locate the **Input Entities** section. Under **Selections to add**, click **+ Add**.

5 In the **Add** dialog box, in the **Selections to add** list, choose **Box 8 - Rotor tip edge 1** and **Box 9 - Rotor tip edge 2**.

6 Click **OK**.

Union 5 - Rotor Tip Edges -X AC

1 In the **Definitions** toolbar, click  **Union**.

2 In the **Settings** window for **Union**, type Union 5 - Rotor Tip Edges -X AC in the **Label** text field.

3 Locate the **Geometric Entity Level** section. From the **Level** list, choose **Edge**.

4 Locate the **Input Entities** section. Under **Selections to add**, click **+ Add**.

5 In the **Add** dialog box, in the **Selections to add** list, choose **Box 10 - Rotor tip edge 3** and **Box 11 - Rotor tip edge 4**.

6 Click **OK**.

Union 6 - Rotor Tip Edges

1 In the **Definitions** toolbar, click  **Union**.

- 2 In the **Settings** window for **Union**, type Union 6 - Rotor Tip Edges in the **Label** text field.
- 3 Locate the **Geometric Entity Level** section. From the **Level** list, choose **Edge**.
- 4 Locate the **Input Entities** section. Under **Selections to add**, click **+ Add**.
- 5 In the **Add** dialog box, in the **Selections to add** list, choose **Union 2 - Rotor Tip Edges + X DC** and **Union 3 - Rotor Tip Edges -X DC**.
- 6 Click **OK**.

Create selections for meshing.

Box 13 - $x > 0$ Beam base

- 1 In the **Definitions** toolbar, click  **Box**.
- 2 In the **Settings** window for **Box**, type Box 13 - $x > 0$ Beam base in the **Label** text field.
- 3 Locate the **Geometric Entity Level** section. From the **Level** list, choose **Boundary**.
- 4 Locate the **Box Limits** section. In the **x minimum** text field, type -delta.
- 5 In the **z minimum** text field, type -delta.
- 6 In the **z maximum** text field, type delta.
- 7 Locate the **Output Entities** section. From the **Include entity if** list, choose **Entity inside box**.

Box 13 - $x \geq 0$ Beam base

Right-click **Box 13 - $x \geq 0$ Beam base** and choose **Duplicate**.

Box 14 - $x < 0$ Beam base

- 1 In the **Model Builder** window, under **Component 1 (comp1)>Definitions>Selections** click **Box 13 - $x \geq 0$ Beam base I**.
- 2 In the **Settings** window for **Box**, type Box 14 - $x < 0$ Beam base in the **Label** text field.
- 3 Locate the **Box Limits** section. In the **x minimum** text field, type -Inf.
- 4 In the **x maximum** text field, type delta.
- 5 Right-click **Box 14 - $x < 0$ Beam base** and choose **Duplicate**.

Box 15 - $x > 0$ Spring Anchor

- 1 In the **Model Builder** window, under **Component 1 (comp1)>Definitions>Selections** click **Box 14 - $x < 0$ Beam base I**.
- 2 In the **Settings** window for **Box**, type Box 15 - $x > 0$ Spring Anchor in the **Label** text field.

- 3 Locate the **Box Limits** section. In the **x minimum** text field, type $-\text{delta}+\text{tether}_x-\text{w_anchor}/2$.
- 4 In the **x maximum** text field, type $\text{delta}+\text{tether}_x+\text{w_anchor}/2$.

Box 15 - x 0 Spring Anchor

Right-click **Box 15 - x 0 Spring Anchor** and choose **Duplicate**.

Box 16 - x < 0 Spring Anchor

- 1 In the **Model Builder** window, under **Component 1 (comp1)>Definitions>Selections** click **Box 15 - x 0 Spring Anchor I**.
- 2 In the **Settings** window for **Box**, type **Box 16 - x < 0 Spring Anchor** in the **Label** text field.
- 3 Locate the **Box Limits** section. In the **x minimum** text field, type $-\text{delta}-\text{tether}_x-\text{w_anchor}/2$.
- 4 In the **x maximum** text field, type $\text{delta}-\text{tether}_x+\text{w_anchor}/2$.

Intersection 3 - Quad Mesh - Springs Construction

- 1 In the **Definitions** toolbar, click  **Intersection**.
- 2 In the **Settings** window for **Intersection**, type **Intersection 3 - Quad Mesh - Springs Construction** in the **Label** text field.
- 3 Locate the **Geometric Entity Level** section. From the **Level** list, choose **Boundary**.
- 4 Locate the **Input Entities** section. Under **Selections to intersect**, click **+ Add**.
- 5 In the **Add** dialog box, in the **Selections to intersect** list, choose **Box 13 - x > 0 Beam base** and **Extrude 3 - Springs**.
- 6 Click **OK**.

Intersection 4 - Quad Mesh - Springs Construction copy

- 1 In the **Definitions** toolbar, click  **Intersection**.
- 2 In the **Settings** window for **Intersection**, type **Intersection 4 - Quad Mesh - Springs Construction copy** in the **Label** text field.
- 3 Locate the **Geometric Entity Level** section. From the **Level** list, choose **Boundary**.
- 4 Locate the **Input Entities** section. Under **Selections to intersect**, click **+ Add**.
- 5 In the **Add** dialog box, in the **Selections to intersect** list, choose **Box 14 - x < 0 Beam base** and **Extrude 3 - Springs**.
- 6 Click **OK**.

Intersection 5 - Mapped Mesh - Anchors

- 1 In the **Definitions** toolbar, click  **Intersection**.
- 2 In the **Settings** window for **Intersection**, type Intersection 5 - Mapped Mesh - Anchors in the **Label** text field.
- 3 Locate the **Geometric Entity Level** section. From the **Level** list, choose **Boundary**.
- 4 Locate the **Input Entities** section. Under **Selections to intersect**, click **+ Add**.
- 5 In the **Add** dialog box, in the **Selections to intersect** list, choose **Box 15 - x > 0 Spring Anchor** and **Extrude 2 - Anchors**.
- 6 Click **OK**.

Intersection 6 - Mapped Mesh - Anchors copy

- 1 In the **Definitions** toolbar, click  **Intersection**.
- 2 In the **Settings** window for **Intersection**, type Intersection 6 - Mapped Mesh - Anchors copy in the **Label** text field.
- 3 Locate the **Geometric Entity Level** section. From the **Level** list, choose **Boundary**.
- 4 Locate the **Input Entities** section. Under **Selections to intersect**, click **+ Add**.
- 5 In the **Add** dialog box, in the **Selections to intersect** list, choose **Box 16 - x < 0 Spring Anchor** and **Extrude 2 - Anchors**.
- 6 Click **OK**.

Intersection 7 - Triangular Mesh - Mass

- 1 In the **Definitions** toolbar, click  **Intersection**.
- 2 In the **Settings** window for **Intersection**, type Intersection 7 - Triangular Mesh - Mass in the **Label** text field.
- 3 Locate the **Geometric Entity Level** section. From the **Level** list, choose **Boundary**.
- 4 Locate the **Input Entities** section. Under **Selections to intersect**, click **+ Add**.
- 5 In the **Add** dialog box, in the **Selections to intersect** list, choose **Box 13 - x > 0 Beam base** and **Extrude 1 - Mass**.
- 6 Click **OK**.

Intersection 8 - Triangular Mesh - Mass copy

- 1 In the **Definitions** toolbar, click  **Intersection**.
- 2 In the **Settings** window for **Intersection**, type Intersection 8 - Triangular Mesh - Mass copy in the **Label** text field.
- 3 Locate the **Geometric Entity Level** section. From the **Level** list, choose **Boundary**.
- 4 Locate the **Input Entities** section. Under **Selections to intersect**, click **+ Add**.

5 In the **Add** dialog box, in the **Selections to intersect** list, choose **Box I4 - x < 0 Beam base** and **Extrude I - Mass**.

6 Click **OK**.

Difference 1 - Quad Mesh - Springs

1 In the **Definitions** toolbar, click  **Difference**.

2 In the **Settings** window for **Difference**, type **Difference 1 - Quad Mesh - Springs** in the **Label** text field.

3 Locate the **Geometric Entity Level** section. From the **Level** list, choose **Boundary**.

4 Locate the **Input Entities** section. Under **Selections to add**, click **+ Add**.

5 In the **Add** dialog box, select **Intersection 3 - Quad Mesh - Springs Construction** in the **Selections to add** list.

6 Click **OK**.

7 In the **Settings** window for **Difference**, locate the **Input Entities** section.

8 Under **Selections to subtract**, click **+ Add**.

9 In the **Add** dialog box, select **Intersection 5 - Mapped Mesh - Anchors** in the **Selections to subtract** list.

10 Click **OK**.

Difference 2 - Quad Mesh - Springs copy

1 In the **Definitions** toolbar, click  **Difference**.

2 In the **Settings** window for **Difference**, type **Difference 2 - Quad Mesh - Springs copy** in the **Label** text field.

3 Locate the **Geometric Entity Level** section. From the **Level** list, choose **Boundary**.

4 Locate the **Input Entities** section. Under **Selections to add**, click **+ Add**.

5 In the **Add** dialog box, select **Intersection 4 - Quad Mesh - Springs Construction copy** in the **Selections to add** list.

6 Click **OK**.



7 In the **Settings** window for **Difference**, locate the **Input Entities** section.

8 Under **Selections to subtract**, click **+ Add**.



9 In the **Add** dialog box, select **Intersection 6 - Mapped Mesh - Anchors copy** in the **Selections to subtract** list.

10 Click **OK**.

Difference 3 - Quad Mesh -Stator & Comb

- 1 In the **Definitions** toolbar, click  **Difference**.
- 2 In the **Settings** window for **Difference**, type Difference 3 - Quad Mesh -Stator & Comb in the **Label** text field.
- 3 Locate the **Geometric Entity Level** section. From the **Level** list, choose **Boundary**.
- 4 Locate the **Input Entities** section. Under **Selections to add**, click  **Add**.
- 5 In the **Add** dialog box, select **Box 13 - $x > 0$ Beam base** in the **Selections to add** list.
- 6 Click **OK**.
- 7 In the **Settings** window for **Difference**, locate the **Input Entities** section.
- 8 Under **Selections to subtract**, click  **Add**.
- 9 In the **Add** dialog box, in the **Selections to subtract** list, choose **Box 15 - $x > 0$ Spring Anchor, Extrude 1 - Mass, Extrude 3 - Springs, and Work Plane 6 - Sense Electrodes**.
- 10 Click **OK**.

Difference 4 - Quad Mesh -Stator & Comb copy

- 1 In the **Definitions** toolbar, click  **Difference**.
- 2 In the **Settings** window for **Difference**, type Difference 4 - Quad Mesh -Stator & Comb copy in the **Label** text field.
- 3 Locate the **Geometric Entity Level** section. From the **Level** list, choose **Boundary**.
- 4 Locate the **Input Entities** section. Under **Selections to add**, click  **Add**.
- 5 In the **Add** dialog box, select **Box 14 - $x < 0$ Beam base** in the **Selections to add** list.
- 6 Click **OK**.
- 7 In the **Settings** window for **Difference**, locate the **Input Entities** section.
- 8 Under **Selections to subtract**, click  **Add**.
- 9 In the **Add** dialog box, in the **Selections to subtract** list, choose **Box 16 - $x < 0$ Spring Anchor, Extrude 1 - Mass, Extrude 3 - Springs, and Work Plane 6 - Sense Electrodes**.
- 10 Click **OK**.

Box 17 - $x > 0$ Anchor base

- 1 In the **Definitions** toolbar, click  **Box**.
- 2 In the **Settings** window for **Box**, type Box 17 - $x > 0$ Anchor base in the **Label** text field.
- 3 Locate the **Geometric Entity Level** section. From the **Level** list, choose **Boundary**.

- 4 Locate the **Box Limits** section. In the **x minimum** text field, type $-\delta$.
- 5 In the **z minimum** text field, type $-\delta - t_{\text{anchor}}$.
- 6 In the **z maximum** text field, type $\delta - t_{\text{anchor}}$.
- 7 Locate the **Output Entities** section. From the **Include entity if** list, choose **Entity inside box**.

Box 17 - $x \geq 0$ Anchor base

Right-click **Box 17 - $x \geq 0$ Anchor base** and choose **Duplicate**.

Box 18 - $x < 0$ Anchor base

- 1 In the **Model Builder** window, under **Component 1 (comp1)>Definitions>Selections** click **Box 17 - $x \geq 0$ Anchor base 1**.
- 2 In the **Settings** window for **Box**, type *Box 18 - $x < 0$ Anchor base* in the **Label** text field.
- 3 Locate the **Box Limits** section. In the **x minimum** text field, type $-\text{Inf}$.
- 4 In the **x maximum** text field, type δ .

Intersection 9 - Triangular Mesh - Sense Electrode

- 1 In the **Definitions** toolbar, click  **Intersection**.
- 2 In the **Settings** window for **Intersection**, type *Intersection 9 - Triangular Mesh - Sense Electrode* in the **Label** text field.
- 3 Locate the **Geometric Entity Level** section. From the **Level** list, choose **Boundary**.
- 4 Locate the **Input Entities** section. Under **Selections to intersect**, click **+ Add**.
- 5 In the **Add** dialog box, in the **Selections to intersect** list, choose **Box 17 - $x \geq 0$ Anchor base** and **Work Plane 6 - Sense Electrodes**.
- 6 Click **OK**.

Intersection 10 - Triangular Mesh - Sense Electrode copy

- 1 In the **Definitions** toolbar, click  **Intersection**.
- 2 In the **Settings** window for **Intersection**, type *Intersection 10 - Triangular Mesh - Sense Electrode copy* in the **Label** text field.
- 3 Locate the **Geometric Entity Level** section. From the **Level** list, choose **Boundary**.
- 4 Locate the **Input Entities** section. Under **Selections to intersect**, click **+ Add**.
- 5 In the **Add** dialog box, in the **Selections to intersect** list, choose **Box 18 - $x < 0$ Anchor base** and **Work Plane 6 - Sense Electrodes**.
- 6 Click **OK**.

Finally create selection for the effective regions of the lower electrodes.

Box 19 - $x > 0$ Lower electrode effective region

- 1 In the **Definitions** toolbar, click  **Box**.
- 2 In the **Settings** window for **Box**, type Box 19 - $x > 0$ Lower electrode effective region in the **Label** text field.
- 3 Locate the **Geometric Entity Level** section. From the **Level** list, choose **Boundary**.
- 4 Locate the **Box Limits** section. In the **x minimum** text field, type $-\text{delta} + y_spring_1 / 2 - \text{electrode_ratio} * l_mass / 2$.
- 5 In the **x maximum** text field, type $\text{delta} + y_spring_1 / 2 + \text{electrode_ratio} * l_mass / 2$.
- 6 In the **y minimum** text field, type $-\text{delta} - \text{electrode_ratio} * w_mass / 2$.
- 7 In the **y maximum** text field, type $\text{delta} + \text{electrode_ratio} * w_mass / 2$.
- 8 In the **z minimum** text field, type $-\text{delta}$.
- 9 In the **z maximum** text field, type delta .
- 10 Locate the **Output Entities** section. From the **Include entity if** list, choose **Entity inside box**.



Box 19 - $x < 0$ Lower electrode effective region

Right-click **Box 19 - $x < 0$ Lower electrode effective region** and choose **Duplicate**.

Box 20 - $x < 0$ Lower electrode effective region

- 1 In the **Model Builder** window, under **Component 1 (comp1) > Definitions > Selections** click **Box 19 - $x < 0$ Lower electrode effective region 1**.
- 2 In the **Settings** window for **Box**, type Box 20 - $x < 0$ Lower electrode effective region in the **Label** text field.
- 3 Locate the **Box Limits** section. In the **x minimum** text field, type $-\text{delta} - y_spring_1 / 2 - \text{electrode_ratio} * l_mass / 2$.
- 4 In the **x maximum** text field, type $\text{delta} - y_spring_1 / 2 + \text{electrode_ratio} * l_mass / 2$.

Union 7 - Lower electrode effective region

- 1 In the **Definitions** toolbar, click  **Union**.
- 2 In the **Settings** window for **Union**, type Union 7 - Lower electrode effective region in the **Label** text field.
- 3 Locate the **Geometric Entity Level** section. From the **Level** list, choose **Boundary**.
- 4 Locate the **Input Entities** section. Under **Selections to add**, click  **Add**.

- 5 In the **Add** dialog box, in the **Selections to add** list, choose **Box 19 - x > 0 Lower electrode effective region** and **Box 20 - x < 0 Lower electrode effective region**.

- 6 Click **OK**.

While a predefined, fully-coupled Electromechanics multiphysics is available, in this model we demonstrate the use of analytic formulas for computing the electrostatic forces. Create extrusion and integration operators to be used in the analytic formulas.

- 7 In the **Model Builder** window, collapse the **Component 1 (comp1)>Definitions>Selections** node.

General Extrusion 1 - Stator Walls

- 1 In the **Definitions** toolbar, click  **Nonlocal Couplings** and choose **General Extrusion**.
- 2 In the **Settings** window for **General Extrusion**, type **General Extrusion 1 - Stator Walls** in the **Label** text field.
- 3 In the **Operator name** text field, type **genextcmb**.
- 4 Locate the **Source Selection** section. From the **Geometric entity level** list, choose **Boundary**.
- 5 From the **Selection** list, choose **Intersection 2 - Stator Vertical Walls**.
- 6 Locate the **Source** section. Select the **Use source map** check box.
- 7 Click to expand the **Advanced** section. From the **Mesh search method** list, choose **Closest point**.

This extrusion operator will be used to compute the distance between the tips of the rotors to the vertical walls of the stators as part of the comb-drive force and capacitance calculation.

- 8 Right-click **General Extrusion 1 - Stator Walls** and choose **Duplicate**.

General Extrusion 2 - Sense Electrodes

- 1 In the **Model Builder** window, under **Component 1 (comp1)>Definitions** click **General Extrusion 1 - Stator Walls 1 (genextcmb2)**.
- 2 In the **Settings** window for **General Extrusion**, type **General Extrusion 2 - Sense Electrodes** in the **Label** text field.
- 3 In the **Operator name** text field, type **genextpp**.
- 4 Locate the **Source Selection** section. From the **Selection** list, choose **Work Plane 6 - Sense Electrodes**.

This extrusion operator will be used to compute the distance between the sense electrodes to the bottom surfaces of the proof masses as part of the parallel-plate force and capacitance calculation.

Integration 1 - Lower Electrodes

- 1 In the **Definitions** toolbar, click  **Nonlocal Couplings** and choose **Integration**.
- 2 In the **Settings** window for **Integration**, type Integration 1 - Lower Electrodes in the **Label** text field.
- 3 In the **Operator name** text field, type intoppp.
- 4 Locate the **Source Selection** section. From the **Geometric entity level** list, choose **Boundary**.
- 5 From the **Selection** list, choose **Union 7 - Lower electrode effective region**.

Integration 2 - Comb Edges

- 1 In the **Definitions** toolbar, click  **Nonlocal Couplings** and choose **Integration**.
- 2 In the **Settings** window for **Integration**, type Integration 2 - Comb Edges in the **Label** text field.
- 3 In the **Operator name** text field, type intopcomb.
- 4 Locate the **Source Selection** section. From the **Geometric entity level** list, choose **Edge**.
- 5 From the **Selection** list, choose **Union 6 - Rotor Tip Edges**.

Now we are ready to enter the analytic formulas and other useful variables, first for the sense electrodes. Note how the extrusion operator is used to compute the gap distance between the parallel plate electrodes. Also a spatially dependent variable, *sign*, is created to provide the correct phase factor for the estimation of the sense mode amplitude (to be performed during postprocessing). The formula for the force on the parallel plate capacitor can be found in standard textbooks such as Ref. 2 (Chapter 15).

Variables 1 - Sense Capacitor

- 1 In the **Model Builder** window, right-click **Definitions** and choose **Variables**.
- 2 In the **Settings** window for **Variables**, type Variables 1 - Sense Capacitor in the **Label** text field.
- 3 Locate the **Geometric Entity Selection** section. From the **Geometric entity level** list, choose **Boundary**.
- 4 From the **Selection** list, choose **Union 7 - Lower electrode effective region**.

5 Locate the **Variables** section. In the table, enter the following settings:

Name	Expression	Unit	Description
dpp_x	genextpp(X) - (X+u)	m	Vector from lower electrode, x
dpp_y	genextpp(Y) - (Y+v)	m	Vector from lower electrode, y
dpp_z	genextpp(Z) - (Z+w)	m	Vector from lower electrode, z
dpp_sq	dpp_x^2+dpp_y^2+dpp_z^2	m ²	Square of parallel plate distance
F_A	0.5*epsilon0_const*Vbase^2/dpp_sq	Pa	Force per unit area of electrode
C_A	epsilon0_const/sqrt(dpp_sq)	F/m ²	Capacitance per unit area of electrode

Variables 2 - Sense Capacitor + sign AC

- 1 Right-click **Definitions** and choose **Variables**.
- 2 In the **Settings** window for **Variables**, type Variables 2 - Sense Capacitor + sign AC in the **Label** text field.
- 3 Locate the **Geometric Entity Selection** section. From the **Geometric entity level** list, choose **Boundary**.
- 4 From the **Selection** list, choose **Box 20 - x < 0 Lower electrode effective region**.
- 5 Locate the **Variables** section. In the table, enter the following settings:

Name	Expression	Unit	Description
sign	1		Sign of capacitance change

- 6 Right-click **Variables 2 - Sense Capacitor + sign AC** and choose **Duplicate**.

Variables 3 - Sense Capacitor - sign AC

- 1 In the **Model Builder** window, under **Component 1 (comp1)>Definitions** click **Variables 2 - Sense Capacitor + sign AC 1**.
- 2 In the **Settings** window for **Variables**, type Variables 3 - Sense Capacitor - sign AC in the **Label** text field.
- 3 Locate the **Geometric Entity Selection** section. From the **Selection** list, choose **Box 19 - x > 0 Lower electrode effective region**.

4 Locate the **Variables** section. In the table, enter the following settings:

Name	Expression	Unit	Description
sign	-1		Sign of capacitance change

Then for the comb drives. Here since the force directions of the combs are different between the DC bias and the AC drive, two spatially dependent variables, **sign** and **AC**, are used to provide correct directions and phase factors. The **linper** operator is used to delineate the AC part of the drive voltage V_{ac} . In addition, the parameter **AC_on** is used to turn the AC drive on or off. The formula for the comb drive force can be found in standard textbooks such as Ref. 2 (Chapter 15). The formula gives the overall force from energy arguments. This overall force can be divided up into separate contributions in different parts of the model in various ways. In this model we choose to divide the overall force into edge loads at the tips of the rotors. Note how the extrusion operator is used to compute the distance between the edges and the vertical walls of the stators as part of the force calculation.

Variables 4 - Comb Drives

- 1 In the **Model Builder** window, right-click **Definitions** and choose **Variables**.
- 2 In the **Settings** window for **Variables**, type **Variables 4 - Comb Drives** in the **Label** text field.
- 3 Locate the **Geometric Entity Selection** section. From the **Geometric entity level** list, choose **Edge**.
- 4 From the **Selection** list, choose **Union 6 - Rotor Tip Edges**.
- 5 Locate the **Variables** section. In the table, enter the following settings:

Name	Expression	Unit	Description
dcmb_x	$\text{genextcmb}(X+u) - (X+u)$	m	Vector from rotor comb edge, x
dcmb_y	$\text{genextcmb}(Y+v) - (Y+v)$	m	Vector from rotor comb edge, y
dcmb_z	$\text{genextcmb}(Z+w) - (Z+w)$	m	Vector from rotor comb edge, z
dcmb	$\text{sqrt}(\text{dcmb}_x^2 + \text{dcmb}_y^2 + \text{dcmb}_z^2)$	m	Parallel plate distance

Name	Expression	Unit	Description
Vtot	$V_{comb} + AC_{on} * AC * \text{linper}(V_{ac})$		Total voltage
F_1	$\text{sign} * 0.5 * \epsilon_0 \text{const} * V_{tot}^2 / d_{cmb}$		Force per unit length of edge
C_1	$\text{linpoint}(\epsilon_0 \text{const} / d_{cmb}) * u * \text{sign} * AC$		Capacitance change per unit length

Variables 5 - Comb Drives + sign DC

- 1 Right-click **Definitions** and choose **Variables**.
- 2 In the **Settings** window for **Variables**, type Variables 5 - Comb Drives + sign DC in the **Label** text field.
- 3 Locate the **Geometric Entity Selection** section. From the **Geometric entity level** list, choose **Edge**.
- 4 From the **Selection** list, choose **Union 2 - Rotor Tip Edges +X DC**.
- 5 Locate the **Variables** section. In the table, enter the following settings:

Name	Expression	Unit	Description
sign	1		Sign of comb drive force

- 6 Right-click **Variables 5 - Comb Drives + sign DC** and choose **Duplicate**.

Variables 6 - Comb Drives - sign DC

- 1 In the **Model Builder** window, under **Component 1 (comp1)>Definitions** click **Variables 5 - Comb Drives + sign DC 1**.
- 2 In the **Settings** window for **Variables**, type Variables 6 - Comb Drives - sign DC in the **Label** text field.
- 3 Locate the **Geometric Entity Selection** section. From the **Selection** list, choose **Union 3 - Rotor Tip Edges -X DC**.
- 4 Locate the **Variables** section. In the table, enter the following settings:

Name	Expression	Unit	Description
sign	-1		Sign of comb drive force

Variables 7 - Comb Drives + sign AC

- 1 In the **Model Builder** window, right-click **Definitions** and choose **Variables**.

- 2 In the **Settings** window for **Variables**, type Variables 7 - Comb Drives + sign AC in the **Label** text field.
- 3 Locate the **Geometric Entity Selection** section. From the **Geometric entity level** list, choose **Edge**.
- 4 From the **Selection** list, choose **Union 4 - Rotor Tip Edges +X AC**.
- 5 Locate the **Variables** section. In the table, enter the following settings:

Name	Expression	Unit	Description
AC	1		Sign of AC comb voltage

- 6 Right-click **Variables 7 - Comb Drives + sign AC** and choose **Duplicate**.



Variables 8 - Comb Drives - sign AC

- 1 In the **Model Builder** window, under **Component 1 (comp1)>Definitions** click **Variables 7 - Comb Drives + sign AC 1**.
- 2 In the **Settings** window for **Variables**, type Variables 8 - Comb Drives - sign AC in the **Label** text field.
- 3 Locate the **Geometric Entity Selection** section. From the **Selection** list, choose **Union 5 - Rotor Tip Edges -X AC**.
- 4 Locate the **Variables** section. In the table, enter the following settings:

Name	Expression	Unit	Description
AC	-1		Sign of AC comb voltage

Now add the Polycrystalline Silicon material from the library.

ADD MATERIAL

- 1 In the **Home** toolbar, click  **Add Material** to open the **Add Material** window.
- 2 Go to the **Add Material** window.
- 3 In the tree, select **MEMS>Semiconductors>Si - Polycrystalline silicon**.
- 4 Click **Add to Component** in the window toolbar.
- 5 In the **Home** toolbar, click  **Add Material** to close the **Add Material** window.

Configure the physics settings. Use the previously defined variables for the electrostatic forces. Turn on the **Coriolis Force** option.

SOLID MECHANICS (SOLID)

Linear Elastic Material 1

In the **Model Builder** window, under **Component 1 (comp1)>Solid Mechanics (solid)** click **Linear Elastic Material 1**.

Damping 1

- 1 In the **Physics** toolbar, click  **Attributes** and choose **Damping**.
- 2 In the **Settings** window for **Damping**, locate the **Damping Settings** section.
- 3 From the **Damping type** list, choose **Isotropic loss factor**.
- 4 From the η_s list, choose **User defined**. In the associated text field, type 1/0.

Fixed Constraint 1

- 1 In the **Physics** toolbar, click  **Boundaries** and choose **Fixed Constraint**.
- 2 In the **Settings** window for **Fixed Constraint**, locate the **Boundary Selection** section.
- 3 From the **Selection** list, choose **Box 3 - Anchor base**.

Boundary Load 1 - Sense Electrodes

- 1 In the **Physics** toolbar, click  **Boundaries** and choose **Boundary Load**.
- 2 In the **Settings** window for **Boundary Load**, type Boundary Load 1 - Sense Electrodes in the **Label** text field.
- 3 Locate the **Boundary Selection** section. From the **Selection** list, choose **Union 7 - Lower electrode effective region**.
- 4 Locate the **Force** section. Specify the \mathbf{F}_A vector as

$$\begin{array}{|c|c|} \hline -F_A & z \\ \hline \end{array}$$

Edge Load 1 - Comb Drives

- 1 In the **Physics** toolbar, click  **Edges** and choose **Edge Load**.
- 2 In the **Settings** window for **Edge Load**, type Edge Load 1 - Comb Drives in the **Label** text field.
- 3 Locate the **Edge Selection** section. From the **Selection** list, choose **Union 6 - Rotor Tip Edges**.
- 4 Locate the **Force** section. Specify the \mathbf{F}_L vector as

$$\begin{array}{|c|c|} \hline F_{1} & x \\ \hline \end{array}$$

Rotating Frame 1

- 1 In the **Physics** toolbar, click  **Domains** and choose **Rotating Frame**.

- 2 In the **Settings** window for **Rotating Frame**, locate the **Rotating Frame** section.
- 3 From the **Axis of rotation** list, choose **y-axis**.
- 4 In the Ω text field, type Ω .
- 5 Locate the **Frame Acceleration Effect** section. Select the **Coriolis force** check box.

Set up the mesh. To save time and file size, a somewhat coarse mesh is used. Nevertheless the mesh is parameterized to be ready for refinement studies. In the followup model, the **Deformed Geometry** feature will be used to study the effects of manufacturing tolerances, with the advantage that it keeps the same mesh while varying the geometry, thus avoiding unwanted variations caused by a different mesh being used for a different geometry.

MESH I

Mapped I

- 1 In the **Mesh** toolbar, click  **More Generators** and choose **Mapped**.
- 2 In the **Settings** window for **Mapped**, locate the **Boundary Selection** section.
- 3 From the **Selection** list, choose **Box 15 - x > 0 Spring Anchor**.

Size I

- 1 Right-click **Mapped I** and choose **Size**.
- 2 In the **Settings** window for **Size**, locate the **Element Size** section.
- 3 Click the **Custom** button.
- 4 Locate the **Element Size Parameters** section.
- 5 Select the **Maximum element size** check box. In the associated text field, type $\text{mesh_factor} * x_spring_w / 2$.
- 6 Select the **Minimum element size** check box. In the associated text field, type $\text{mesh_factor} * x_spring_w / 10$.

Size

- 1 In the **Model Builder** window, under **Component 1 (comp1)>Mesh I** click **Size**.
- 2 In the **Settings** window for **Size**, locate the **Element Size** section.
- 3 Click the **Custom** button.
- 4 Locate the **Element Size Parameters** section. In the **Maximum element size** text field, type $\text{mesh_factor} * \text{tether_w} / 3$.
- 5 In the **Minimum element size** text field, type $\text{mesh_factor} * \text{tether_w} / 30$.
- 6 In the **Maximum element growth rate** text field, type $1.1 + \text{mesh_factor} * 0.2$.

Copy Face 1

- 1 In the **Mesh** toolbar, click  **Copy** and choose **Copy Face**.
- 2 In the **Settings** window for **Copy Face**, locate the **Source Boundaries** section.
- 3 From the **Selection** list, choose **Box 15 - x > 0 Spring Anchor**.
- 4 Locate the **Destination Boundaries** section. From the **Selection** list, choose **Box 16 - x < 0 Spring Anchor**.



Free Quad 1

- 1 In the **Mesh** toolbar, click  **More Generators** and choose **Free Quad**.
- 2 In the **Settings** window for **Free Quad**, locate the **Boundary Selection** section.
- 3 From the **Selection** list, choose **Difference 1 - Quad Mesh - Springs**.

Size 1

- 1 Right-click **Free Quad 1** and choose **Size**.
- 2 In the **Settings** window for **Size**, locate the **Geometric Entity Selection** section.
- 3 Click  **Clear Selection**.
- 4 Select Boundaries 945 and 950 only.
- 5 Locate the **Element Size** section. Click the **Custom** button.
- 6 Locate the **Element Size Parameters** section.
- 7 Select the **Maximum element size** check box. In the associated text field, type `mesh_factor*x_spring_w/3`.
- 8 Select the **Minimum element size** check box. In the associated text field, type `mesh_factor*x_spring_w/30`.

Copy Face 2

- 1 In the **Mesh** toolbar, click  **Copy** and choose **Copy Face**.
- 2 In the **Settings** window for **Copy Face**, locate the **Source Boundaries** section.
- 3 From the **Selection** list, choose **Difference 1 - Quad Mesh - Springs**.
- 4 Locate the **Destination Boundaries** section. From the **Selection** list, choose **Difference 2 - Quad Mesh - Springs copy**.
- 5 Click  **Build Selected**.

Size

In the **Model Builder** window, right-click **Size** and choose **Duplicate**.

Size 1



- 1 In the **Model Builder** window, click **Size 1**.

- 2 In the **Settings** window for **Size**, locate the **Element Size Parameters** section.
- 3 In the **Maximum element size** text field, type $\text{mesh_factor} * w_{\text{rotor}} / 2$.
- 4 In the **Minimum element size** text field, type $\text{mesh_factor} * w_{\text{rotor}} / 20$.

Free Quad 2

- 1 In the **Mesh** toolbar, click  **More Generators** and choose **Free Quad**.
- 2 In the **Settings** window for **Free Quad**, locate the **Boundary Selection** section.
- 3 From the **Selection** list, choose **Difference 3 - Quad Mesh -Stator & Comb**.

Copy Face 3

- 1 In the **Mesh** toolbar, click  **Copy** and choose **Copy Face**.
- 2 In the **Settings** window for **Copy Face**, locate the **Source Boundaries** section.
- 3 From the **Selection** list, choose **Difference 3 - Quad Mesh -Stator & Comb**.
- 4 Locate the **Destination Boundaries** section. From the **Selection** list, choose **Difference 4 - Quad Mesh -Stator & Comb copy**.
- 5 Click  **Build Selected**.

Size 1

Right-click **Size 1** and choose **Duplicate**.

Size 2

- 1 In the **Model Builder** window, click **Size 2**.
- 2 In the **Settings** window for **Size**, locate the **Element Size Parameters** section.
- 3 In the **Maximum element size** text field, type $\text{mesh_factor} * w_{\text{rotor}}$.
- 4 In the **Minimum element size** text field, type $\text{mesh_factor} * w_{\text{rotor}} / 10$.

Free Triangular 1

- 1 In the **Mesh** toolbar, click  **More Generators** and choose **Free Triangular**.
- 2 In the **Settings** window for **Free Triangular**, locate the **Boundary Selection** section.
- 3 From the **Selection** list, choose **Intersection 7 - Triangular Mesh - Mass**.

Copy Face 4

- 1 In the **Mesh** toolbar, click  **Copy** and choose **Copy Face**.
- 2 In the **Settings** window for **Copy Face**, locate the **Source Boundaries** section.
- 3 From the **Selection** list, choose **Intersection 7 - Triangular Mesh - Mass**.
- 4 Locate the **Destination Boundaries** section. From the **Selection** list, choose **Intersection 8 - Triangular Mesh - Mass copy**.

Free Triangular 2

- 1 In the **Mesh** toolbar, click  **More Generators** and choose **Free Triangular**.
- 2 In the **Settings** window for **Free Triangular**, locate the **Boundary Selection** section.
- 3 From the **Selection** list, choose **Intersection 9 - Triangular Mesh - Sense Electrode**.

Copy Face 5

- 1 In the **Mesh** toolbar, click  **Copy** and choose **Copy Face**.
- 2 In the **Settings** window for **Copy Face**, locate the **Source Boundaries** section.
- 3 From the **Selection** list, choose **Intersection 9 - Triangular Mesh - Sense Electrode**.
- 4 Locate the **Destination Boundaries** section. From the **Selection** list, choose **Intersection 10 - Triangular Mesh - Sense Electrode copy**.

Swept 1

- 1 In the **Mesh** toolbar, click  **Swept**.
- 2 In the **Settings** window for **Swept**, locate the **Domain Selection** section.
- 3 From the **Geometric entity level** list, choose **Domain**.
- 4 From the **Selection** list, choose **Box 2 - Entire Beam Layer**.

Distribution 1

- 1 Right-click **Swept 1** and choose **Distribution**.
- 2 In the **Settings** window for **Distribution**, locate the **Distribution** section.
- 3 In the **Number of elements** text field, type $\max(1, \text{floor}(3/\text{mesh_factor}))$.

Swept 2

- 1 In the **Mesh** toolbar, click  **Swept**.
- 2 In the **Settings** window for **Swept**, locate the **Domain Selection** section.
- 3 From the **Geometric entity level** list, choose **Domain**.
- 4 From the **Selection** list, choose **Extrude 2 - Anchors**.

Distribution 1

- 1 Right-click **Swept 2** and choose **Distribution**.
- 2 In the **Settings** window for **Distribution**, locate the **Distribution** section.
- 3 In the **Number of elements** text field, type $\max(1, \text{floor}(3/\text{mesh_factor}))$.

4 In the **Mesh** toolbar, click  **Build Mesh**.

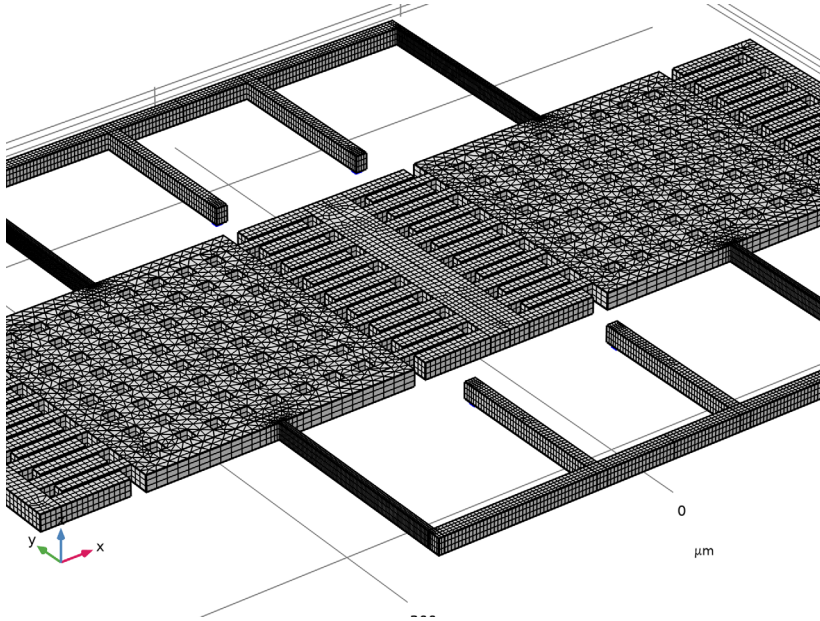

Perform the stationary study.

STUDY 1 - STATIONARY

- 1 In the **Model Builder** window, click **Study 1**.
- 2 In the **Settings** window for **Study**, type Study 1 - Stationary in the **Label** text field.
- 3 In the **Home** toolbar, click  **Compute**.

RESULTS

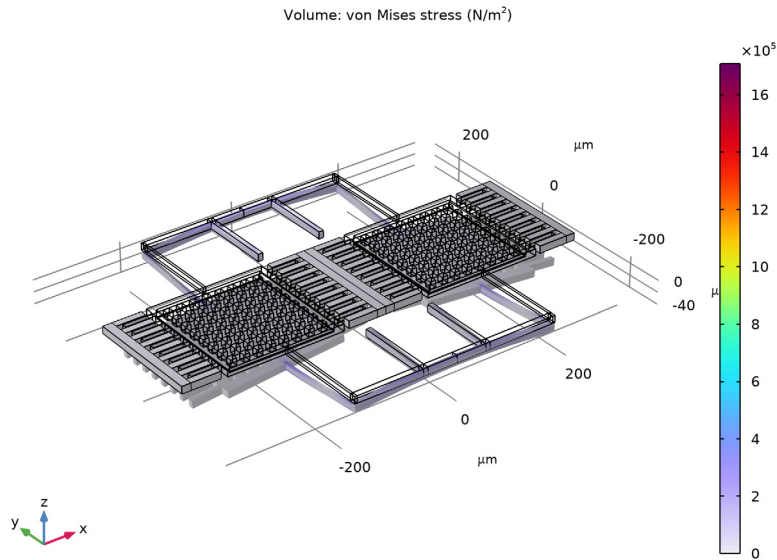

Stress (solid)



The plot shows that the masses are pulled down slightly by the bias voltage of the sense electrodes. The masses do not move horizontally since the DC part of the comb drive forces for each mass are equal and in opposite directions so they cancel out.

Next perform a prestressed eigenfrequency study to find the drive and sense mode frequencies.

ADD STUDY

- 1 In the **Home** toolbar, click  **Add Study** to open the **Add Study** window.
- 2 Go to the **Add Study** window.
- 3 Find the **Studies** subsection. In the **Select Study** tree, select **Preset Studies for Selected Physics Interfaces>Eigenfrequency, Prestressed**.
- 4 Click **Add Study** in the window toolbar.
- 5 In the **Home** toolbar, click  **Add Study** to close the **Add Study** window.

STUDY 2 - PRESTRESSED EIGENFREQUENCY

- 1 In the **Model Builder** window, click **Study 2**.

- 2 In the **Settings** window for **Study**, type Study 2 - Prestressed Eigenfrequency in the **Label** text field.

Step 1: Stationary

- 1 In the **Model Builder** window, under **Study 2 - Prestressed Eigenfrequency** click **Step 1: Stationary**.
- 2 In the **Settings** window for **Stationary**, locate the **Study Settings** section.
- 3 Select the **Include geometric nonlinearity** check box.

Step 2: Eigenfrequency

- 1 In the **Model Builder** window, click **Step 2: Eigenfrequency**.
- 2 In the **Settings** window for **Eigenfrequency**, locate the **Study Settings** section.
- 3 Select the **Desired number of eigenfrequencies** check box. In the associated text field, type 3.
- 4 In the **Search for eigenfrequencies around shift** text field, type 38000[Hz].
- 5 From the **Search method around shift** list, choose **Larger real part**.
- 6 In the **Home** toolbar, click  **Compute**.

RESULTS

Mode Shape (solid)

Eigenfrequency=38262+38.262i Hz Surface: Displacement magnitude (μm)

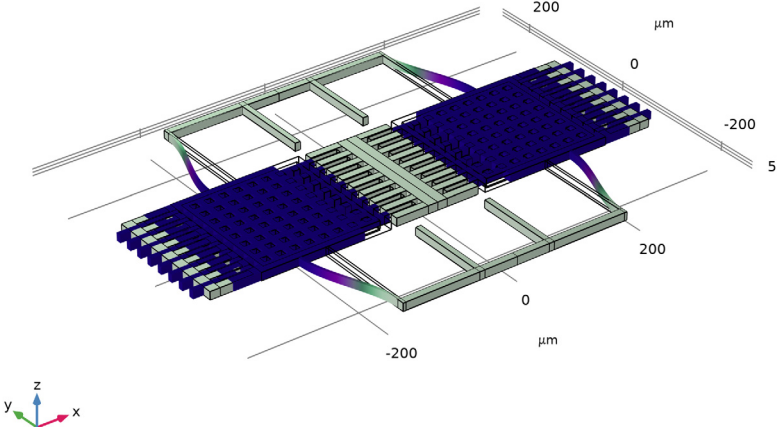

The plot shows the drive mode, ...

1 In the **Settings** window for **3D Plot Group**, click **Plot Next**.

Eigenfrequency=41125+41.498i Hz Surface: Displacement magnitude (μm)

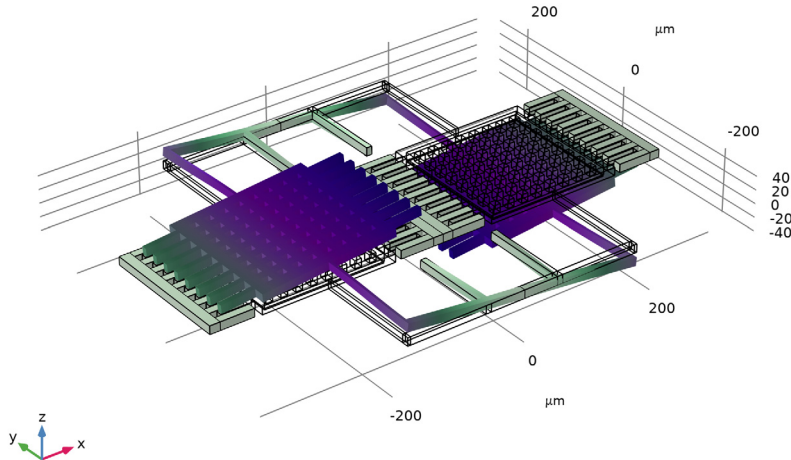

... and the sense mode.

Before continuing to the next study, we use analytic formulas to estimate the drive and sense mode frequencies, to compare with the numerical result. The global parameter table serves well for this kind of back-of-the-envelope calculations. In particular, the capability of including units in the calculation helps detect mistakes. First compute the drive mode. The total mass of the resonator is calculated straightforwardly. The spring constants of each segment of the spring for the drive mode is estimated using standard formulas in textbooks such as Ref. 2 (section 4.3 Spring design equations). From the mode shape of the drive mode, the formula for guided beams is used.

GLOBAL DEFINITIONS

Parameters 3 - Estimate drive mode frequency

- 1 In the **Home** toolbar, click **Pi Parameters** and choose **Add>Parameters**.
- 2 In the **Settings** window for **Parameters**, type Parameters 3 - Estimate drive mode frequency in the **Label** text field.

3 Locate the **Parameters** section. In the table, enter the following settings:

Name	Expression	Value	Description
rho0	2320[kg/m^3]	2320 kg/m ³	Density
m0	rho0*t_beam*2*(2*n_combs*l_rotor*w_rotor+l_mass*w_mass-n_etch_x*n_etch_y*etch_dim^2)	2.2272E-9 kg	Total mass
E0	160e9[Pa]	1.6E11 Pa	Young's modulus
I0	t_beam*x_spring_w^3/12	6.4E-23 m ⁴	Area moment of inertia for X spring in-plane bending
k0	4*12*E0*I0/x_spring_l^3	145.64 N/m	Spring constant for X spring in-plane bending
I1	t_beam*y_spring_w^3/12	1E-21 m ⁴	Area moment of inertia for Y spring in-plane bending
y_spring_l3	y_spring_l/2-tether_x	1.2E-4 m	Length of Y spring between tether and X spring
k1	4*12*E0*I1/y_spring_l3^3	4444.4 N/m	Spring constant for Y spring in-plane bending
k_tot	1/(1/k0+1/k1)	141.01 N/m	Total spring constant for in-plane bending
f0	sqrt(k_tot/m0)/2/pi	40047 1/s	Estimated drive mode frequency

The estimated drive mode frequency of 40 kHz is not too far away from the computed value of 38 kHz. Next the sense mode, which involves both bending and twisting of the springs. Therefore the formulas for both guided beams and torsional springs are used in the estimation.

Parameters 4 - Estimate sense mode frequency

1 In the **Home** toolbar, click **Pi Parameters** and choose **Add>Parameters**.

- 2 In the **Settings** window for **Parameters**, type Parameters 4 - Estimate sense mode frequency in the **Label** text field.

3 Locate the **Parameters** section. In the table, enter the following settings:

Name	Expression	Value	Description
I2	$t_beam^3 * x_spring_w / 12$	$5.76E-22 \text{ m}^4$	Area moment of inertia for X spring out-of-plane bending
k2	$4 * 12 * E0 * I2 / x_spring_l^3$	1310.7 N/m	Spring constant for X spring out-of-plane bending
I3	$t_beam^3 * y_spring_w / 12$	$1.44E-21 \text{ m}^4$	Area moment of inertia for Y spring out-of-plane bending
k3	$4 * 12 * E0 * I3 / y_spring_l^3$	6400 N/m	Spring constant for Y spring out-of-plane bending
I4	$t_beam^3 * tether_w / 12$	$1.152E-21 \text{ m}^4$	Area moment of inertia for tether beam out-of-plane bending
k4	$4 * 12 * E0 * I4 / tether_l^3$	5120 N/m	Spring constant for tether beam out-of-plane bending
G0	80[GPa]	8E10 Pa	Shear modulus
k_th	$G0 * t_beam * tether_w^3 / tether_l * (1/3 - 0.21 * tether_w / t_beam * (1 - ((tether_w / t_beam)^4) / 12))$	8.0133E-7 J	Torsional spring constant of tether beam
k5	$4 * k_th / y_spring_l^3$	222.59 J/m ²	Spring constant from torsion of tether beams
k_tot2	$1 / (1/k2 + 1/k3 + 1/k4 + 1/k5)$	178.35 N/m	Total spring constant for out-of-plane bending
f1	$\sqrt{k_tot2 / m0} / 2 / \pi$	45038 1/s	Estimated sense mode frequency

The estimated sense mode frequency of 45 kHz is also not too far away from the computed value of 41 kHz, especially given the complicated bending and twisting configuration of the sense mode. Now we perform a prestressed frequency domain

study to calculate the drive mode AC amplitude and the sense mode AC signal as a function of the rotation speed. First enter the drive mode frequency from the previous study result into the parameter table.



Parameters 5 - Result from Study 2

- 1 In the **Home** toolbar, click  **Parameters** and choose **Add>Parameters**.
- 2 In the **Settings** window for **Parameters**, type Parameters 5 - Result from Study 2 in the **Label** text field.
- 3 Locate the **Parameters** section. In the table, enter the following settings:

Name	Expression	Value	Description
fd	38262[Hz]	38262 Hz	Drive frequency (from computed drive-mode eigenfrequency)

Then set up the prestressed frequency domain study. Note how the parameter AC_on is used to turn on the AC drive in the second study step (Frequency Domain Perturbation).

ADD STUDY

- 1 In the **Home** toolbar, click  **Add Study** to open the **Add Study** window.
- 2 Go to the **Add Study** window.
- 3 Find the **Studies** subsection. In the **Select Study** tree, select **Preset Studies for Selected Physics Interfaces>Frequency Domain, Prestressed**.
- 4 Click **Add Study** in the window toolbar.
- 5 In the **Home** toolbar, click  **Add Study** to close the **Add Study** window.

STUDY 3 - PRESTRESSED FREQUENCY DOMAIN

- 1 In the **Model Builder** window, click **Study 3**.
- 2 In the **Settings** window for **Study**, type Study 3 - Prestressed Frequency Domain in the **Label** text field.

Step 1: Stationary

- 1 In the **Model Builder** window, under **Study 3 - Prestressed Frequency Domain** click **Step 1: Stationary**.
- 2 In the **Settings** window for **Stationary**, locate the **Study Settings** section.
- 3 Select the **Include geometric nonlinearity** check box.

Step 2: Frequency-Domain Perturbation

- 1 In the **Model Builder** window, click **Step 2: Frequency-Domain Perturbation**.

- 2 In the **Settings** window for **Frequency-Domain Perturbation**, locate the **Study Settings** section.
- 3 In the **Frequencies** text field, type **fd**.
- 4 Click to expand the **Study Extensions** section. Select the **Auxiliary sweep** check box.
- 5 From the **Sweep type** list, choose **All combinations**.
- 6 Click **+ Add**.
- 7 In the table, enter the following settings:

Parameter name	Parameter value list	Parameter unit
AC_on (1 to turn on AC drive, 0 otherwise)	1	

- 8 Click **+ Add**.
- 9 In the table, enter the following settings:

Parameter name	Parameter value list	Parameter unit
Omega (Angular rotation rate)	0 100	deg/s

- 10 In the **Home** toolbar, click **= Compute**.

RESULTS

Stress (solid) I

Create some plots to examine the result. First look at the drive mode amplitude.

- 1 Right-click **Results>Stress (solid) I** and choose **Duplicate**.

Imag X displacement - Drive mode amplitude

- 1 In the **Model Builder** window, under **Results** click **Stress (solid) I.I**.
- 2 In the **Settings** window for **3D Plot Group**, type **Imag X displacement - Drive mode amplitude** in the **Label** text field.
- 3 Click to expand the **Title** section. From the **Title type** list, choose **Manual**.
- 4 In the **Title** text area, type **Drive mode amplitude (μm)**.
- 5 Locate the **Plot Settings** section. From the **Frame** list, choose **Material (X, Y, Z)**.
- 6 Locate the **Color Legend** section. Select the **Show maximum and minimum values** check box.

Volume 1

- 1 In the **Model Builder** window, expand the **Imag X displacement - Drive mode amplitude** node, then click **Volume 1**.
- 2 In the **Settings** window for **Volume**, locate the **Expression** section.
- 3 In the **Expression** text field, type $\text{imag}(u)$.

Deformation

- 1 In the **Model Builder** window, expand the **Volume 1** node, then click **Deformation**.
- 2 In the **Settings** window for **Deformation**, locate the **Expression** section.
- 3 In the **x-component** text field, type $\text{imag}(u)$.
- 4 In the **y-component** text field, type $\text{imag}(v)$.
- 5 In the **z-component** text field, type $\text{imag}(w)$.
- 6 In the **Imag X displacement - Drive mode amplitude** toolbar, click  **Plot**.

freq=38262 Hz, AC_on=1, Omega=100 deg/s Drive mode amplitude (μm)

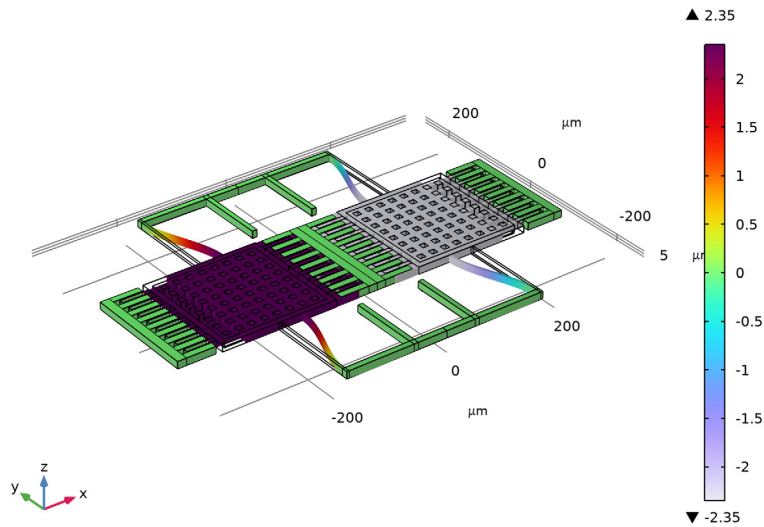

We see that the drive mode amplitude is about 2.4 μm . This can be compared to an estimation using an analytic formula. This gives a good estimate of 2.2 μm (see instructions below). The formula for the amplitude as a function of applied force, Q factor, and spring constant can be found in standard textbooks such as Ref. 2 (Appendix B).

GLOBAL DEFINITIONS

Parameters 6 - Estimate drive mode amplitude

- 1 In the **Home** toolbar, click **P**; **Parameters** and choose **Add>Parameters**.
- 2 In the **Settings** window for **Parameters**, type Parameters 6 - Estimate drive mode amplitude in the **Label** text field.
- 3 Locate the **Parameters** section. In the table, enter the following settings:

Name	Expression	Value	Description
n_overlaps	$2 * n_combs * 4$	64	Total number of comb drive electrode overlaps
F_comb_dc	$n_overlaps * \epsilon_0 * const * t_beam * V_{comb}^2 / (2 * gap_combs)$	6.12E-6 N	DC comb force
F_comb_ac	$2 * F_comb_dc * V_ac / V_{comb}$	6.12E-7 N	AC comb force
u_ac0	$F_comb_ac * Q / k_tot$	2.17E-6 m	Estimated drive mode AC amplitude

Create some plots to look at the sense mode response.

RESULTS

Stress (solid) I

In the **Model Builder** window, under **Results** right-click **Stress (solid) I** and choose **Duplicate**.

Real Z displacement - No rotation

- 1 In the **Model Builder** window, under **Results** click **Stress (solid) I.1**.
- 2 In the **Settings** window for **3D Plot Group**, type Real Z displacement - No rotation in the **Label** text field.
- 3 Locate the **Data** section. From the **Parameter value (Omega (deg/s))** list, choose **0**.
- 4 Locate the **Plot Settings** section. From the **Frame** list, choose **Material (X, Y, Z)**.
- 5 Locate the **Color Legend** section. Select the **Show maximum and minimum values** check box.

Volume I

- 1 In the **Model Builder** window, expand the **Real Z displacement - No rotation** node, then click **Volume I**.
- 2 In the **Settings** window for **Volume**, locate the **Expression** section.

- 3 In the **Expression** text field, type w .
- 4 Clear the **Compute differential** check box.

Deformation

- 1 In the **Model Builder** window, expand the **Volume 1** node, then click **Deformation**.
- 2 In the **Settings** window for **Deformation**, locate the **Expression** section.
- 3 In the **z-component** text field, type $w*1e3$.
- 4 In the **Real Z displacement - No rotation** toolbar, click  **Plot**.

Real Z displacement - No rotation

In the **Model Builder** window, under **Results** right-click **Real Z displacement - No rotation** and choose **Duplicate**.

Real Z Displacement - Rotation

- 1 In the **Model Builder** window, under **Results** click **Real Z displacement - No rotation 1**.
- 2 In the **Settings** window for **3D Plot Group**, type Real Z Displacement - Rotation in the **Label** text field.
- 3 Locate the **Data** section. From the **Parameter value (Omega (deg/s))** list, choose **100**.
- 4 In the **Real Z Displacement - Rotation** toolbar, click  **Plot**.
- 5 Right-click **Real Z Displacement - Rotation** and choose **Duplicate**.

Real Z displacement - Net sense signal

- 1 In the **Model Builder** window, under **Results** click **Real Z Displacement - Rotation 1**.
- 2 In the **Settings** window for **3D Plot Group**, type Real Z displacement - Net sense signal in the **Label** text field.
- 3 Locate the **Title** section. From the **Title type** list, choose **Manual**.
- 4 In the **Title** text area, type Sense mode amplitude (μm).

Volume 1

- 1 In the **Model Builder** window, expand the **Real Z displacement - Net sense signal** node, then click **Volume 1**.
- 2 In the **Settings** window for **Volume**, locate the **Expression** section.
- 3 In the **Expression** text field, type $w\text{-withsol}('sol4',w,\text{setind}(\text{Omega},1))$.

Deformation

- 1 In the **Model Builder** window, expand the **Volume 1** node, then click **Deformation**.
- 2 In the **Settings** window for **Deformation**, locate the **Expression** section.
- 3 In the **x-component** text field, type $u\text{-withsol}('sol4',u,\text{setind}(\text{Omega},1))$.

- 4 In the **y-component** text field, type `v-withsol('sol4',v,setind(Omega,1))`.
- 5 In the **z-component** text field, type `(w-withsol('sol4',w,setind(Omega,1)))*1e3`.
- 6 In the **Real Z displacement - Net sense signal** toolbar, click  **Plot**.

freq=38262 Hz, AC_on=1, Omega=100 deg/s Sense mode amplitude (μm)

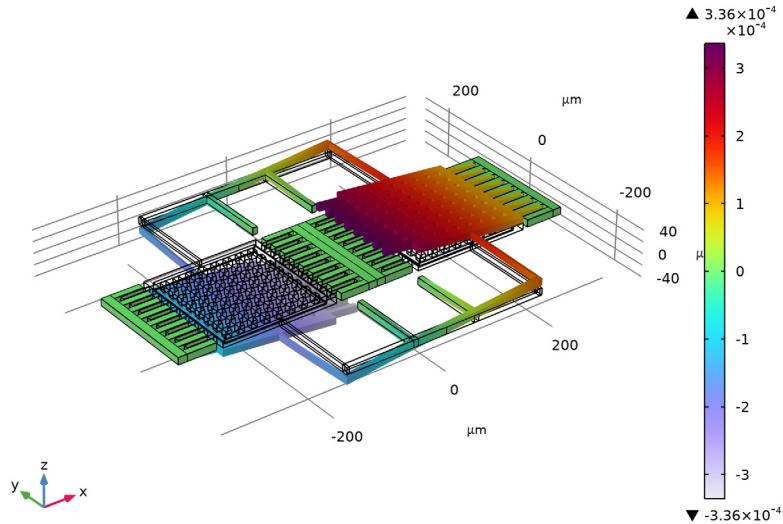

By clicking on the center of each proof mass in the plot and look at the result in the **Evaluation 3D** table, we see that the sense mode amplitude is about 0.20 nm. This can be compared to an estimation using an analytic formula. This gives a good estimate of 0.21 nm (see instructions below). The calculation of the Coriolis force can be found in standard textbooks such as Ref. 2 (Chapter 22).

GLOBAL DEFINITIONS

Parameters 7 - Estimate sense mode amplitude

- 1 In the **Home** toolbar, click  **Parameters** and choose **Add>Parameters**.
- 2 In the **Settings** window for **Parameters**, type Parameters 7 - Estimate sense mode amplitude in the **Label** text field.

3 Locate the **Parameters** section. In the table, enter the following settings:

Name	Expression	Value	Description
fs	41129[Hz]	41129 Hz	Computed sense mode eigenfrequency
k_from_fd	$m0*(2*\pi*fd)^2$	128.72 N/m	Total spring constant from computed drive mode frequency
u_ac0_from_fd	F_comb_ac*Q/k_from_fd	2.3772E-6 m	Drive mode AC amplitude from computed frequency
v_ac0_from_fd	$u_ac0_from_fd*2*\pi*fd$	0.5715 m/s	Drive mode velocity amplitude from computed frequency
F_c	$2*m0*v_ac0_from_fd*100[deg/s]$	4.4431E-9 N	Coriolis force
k_from_fs	$m0*(2*\pi*fs)^2$	148.74 N/m	Spring constant from computed sense mode frequency
u_s_at_fs	F_c*Q/k_from_fs	1.4936E-8 m	Sense mode amplitude if driven at sense frequency
u_s	$u_s_at_fs/\sqrt{1+Q^2*(fd/fs-fs/fd)^2}$	2.0651E-10 m	Estimated sense mode amplitude at drive frequency

As an alternative to reading values off the graphs, in the following steps we show how to use the **Evaluation Group** tool to evaluate the displacement values. First create an average operator and update the solution so that the newly created operator will be recognized by the solution dataset.

DEFINITIONS

Average 1 - Lower Electrodes

- 1 In the **Definitions** toolbar, click  **Nonlocal Couplings** and choose **Average**.
- 2 In the **Settings** window for **Average**, type Average 1 - Lower Electrodes in the **Label** text field.
- 3 In the **Operator name** text field, type aveoppp.
- 4 Locate the **Source Selection** section. From the **Geometric entity level** list, choose **Boundary**.

5 From the **Selection** list, choose **Union 7 - Lower electrode effective region**.

STUDY 1 - STATIONARY

In the **Study** toolbar, click  **Update Solution**.

RESULTS

Evaluation Group 1 - Study 1 - Stationary

1 In the **Results** toolbar, click  **Evaluation Group**.

2 In the **Settings** window for **Evaluation Group**, type Evaluation Group 1 - Study 1 - Stationary in the **Label** text field.

Global Evaluation 1

1 Right-click **Evaluation Group 1 - Study 1 - Stationary** and choose **Global Evaluation**.

2 In the **Settings** window for **Global Evaluation**, locate the **Expressions** section.

3 In the table, enter the following settings:

Expression	Unit	Description
aveoppp(w)	μm	Average Z displacement

4 In the **Evaluation Group 1 - Study 1 - Stationary** toolbar, click  **Evaluate**.

Continue to use the **Evaluation Group** tool to evaluate the drive mode and sense mode amplitudes for the prestressed frequency domain study.

In addition, compute the sensitivity in terms of the sense capacitance change per rotation rate, in the units of aF/(deg/s). Two alternatives are used below. The first one integrates the capacitance per unit area variable C_A defined earlier over the effective region of the lower electrodes. Note the use of the **sign** variable for the AC signal, and the use of the **Compute differential** check box to evaluate the correct small signal amplitude of the variable C_A , which is a nonlinear function of the dependent variables (alternatively, the **lindev** operator can be used with the check box cleared). The other one estimates the capacitance change by taking the derivative of the analytic parallel plate capacitance with respect to the gap size and multiplying by the sense mode amplitude. Both methods produced very similar results. It can be useful to evaluate the sense capacitance amplitude without dividing by the rotation rate, as shown in the last row of the global evaluation table.

STUDY 3 - PRESTRESSED FREQUENCY DOMAIN

In the **Study** toolbar, click  **Update Solution**.

RESULTS

Evaluation Group 1 - Study 1 - Stationary

In the **Model Builder** window, under **Results** right-click **Evaluation Group 1 - Study 1 - Stationary** and choose **Duplicate**.

Evaluation Group 2 - Study 3 - Prestressed Frequency Domain

- 1 In the **Model Builder** window, under **Results** click **Evaluation Group 1 - Study 1 - Stationary 1**.
- 2 In the **Settings** window for **Evaluation Group**, type Evaluation Group 2 - Study 3 - Prestressed Frequency Domain in the **Label** text field.
- 3 Locate the **Data** section. From the **Dataset** list, choose **Study 3 - Prestressed Frequency Domain/Solution 4 (sol4)**.
- 4 From the **Parameter selection (Omega)** list, choose **Last**.

Global Evaluation 1

- 1 In the **Model Builder** window, expand the **Evaluation Group 2 - Study 3 - Prestressed Frequency Domain** node, then click **Global Evaluation 1**.
- 2 In the **Settings** window for **Global Evaluation**, locate the **Expressions** section.
- 3 In the table, enter the following settings:

Expression	Unit	Description
$\text{aveoppp}(\text{imag}(\text{sign}*u))$	μm	Drive mode amplitude
$\text{aveoppp}(\text{real}(\text{sign}*w))$	μm	Sense mode amplitude
$\text{intoppp}(\text{sign}*C_A)/\Omega/1[\text{aF}/(\text{deg/s})]$	1	Sensitivity (aF/(deg/s))
$-\text{aveoppp}(\text{real}(\text{sign}*w))*\text{epsilon0_const}*\text{intoppp}(1)/t_anchor^2/\Omega/1[\text{aF}/(\text{deg/s})]$	1	Estimated sensitivity
$\text{intoppp}(\text{sign}*C_A)$	aF	Sense capacitance amplitude

- 4 Select the **Compute differential** check box.
- 5 In the **Evaluation Group 2 - Study 3 - Prestressed Frequency Domain** toolbar, click  **Evaluate**.