



**Topic for the
COMSOL Conference Munich 2023:**

**Analysis of the stress and load distribution of
an assembled screw
including threaded contact**

**Christoph Hollenbeck
October 2023**

**COMSOL
CONFERENCE
2023 MUNICH**

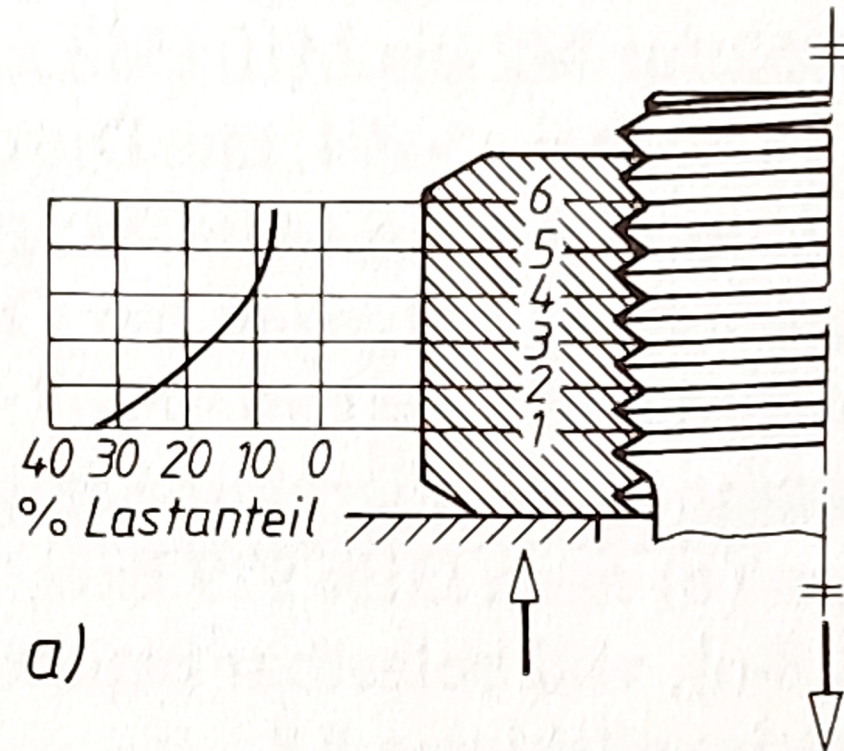

Load distribution of a conventional screw [1]

- In respected reference books it can be read that the load share of the first thread is around one third (with in total six engaged threads):

$$\varphi \approx 1/3 \approx 0.333 \triangleq 33.3 \% \quad (\text{see illustration left})$$

- The averaged load share is $\varphi_{\text{average}} = 1/6 \approx 0.167 \triangleq 16.7 \% \approx 0.5 \cdot 33.3 \%$
- That means, that the load share of the first thread is about two times larger than the average load share.
- The motivation of this work is to determine the load distribution of the threads in a study that is as accurate as possible using the finite element method (FEM) with the aim of possibly being able to determine a more precise load profile.

source of [1]: H. Wittel, D. Muhs, D. Jannasch and J. Voßiek, Roloff/Matek Maschinenelemente, 19th ed., Vieweg+Teubner, 2009 (page 228).

3D – thread in comparison to a 2D – simplification

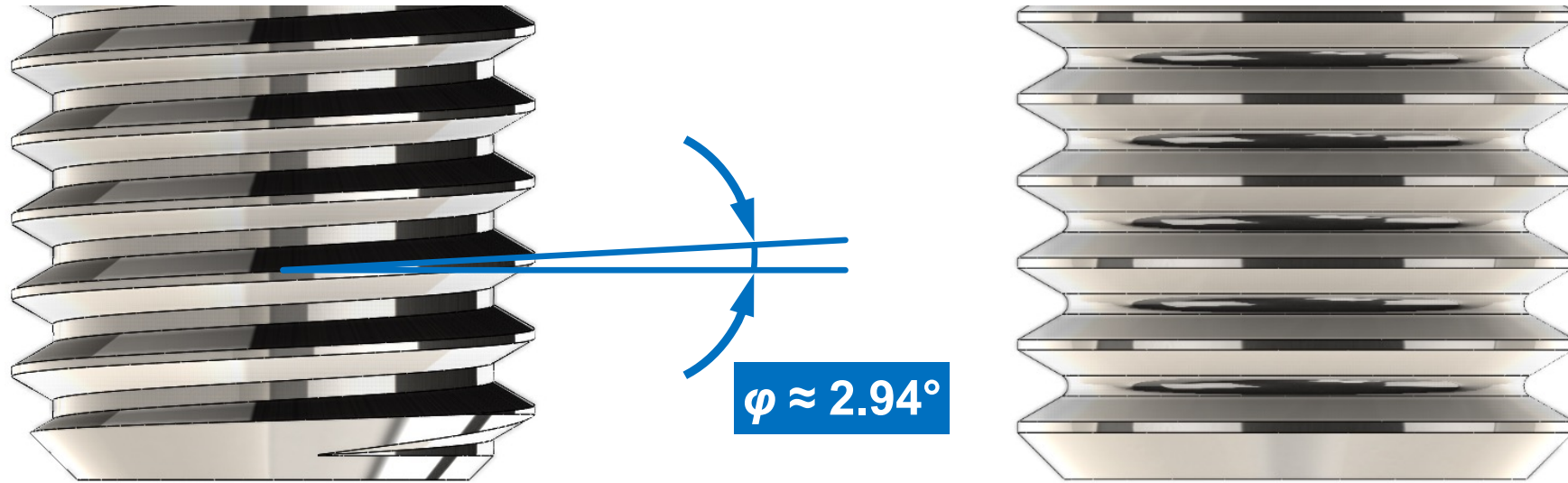

**3D – thread with simplified contour
without root radii**

2D – thread with root radii or core fillets

- The pitch angle of the 3D-thread with respect to the horizontal is only about $\varphi \approx \arctan(P/(\varnothing_{\text{flank}} \cdot \pi)) = \arctan((1.75 \text{ mm})/(10.8633 \text{ mm} \cdot \pi)) \approx 2.94^\circ$.
- This angle is close to zero and it seemed reasonable to make a 2D-axisymmetric simplification.
- This 2D-axisymmetric simplification (see Fig. 1 (right)) opened up the possibility of meshing the geometry very finely and also to consider several variants including nonlinearity of the material, too.

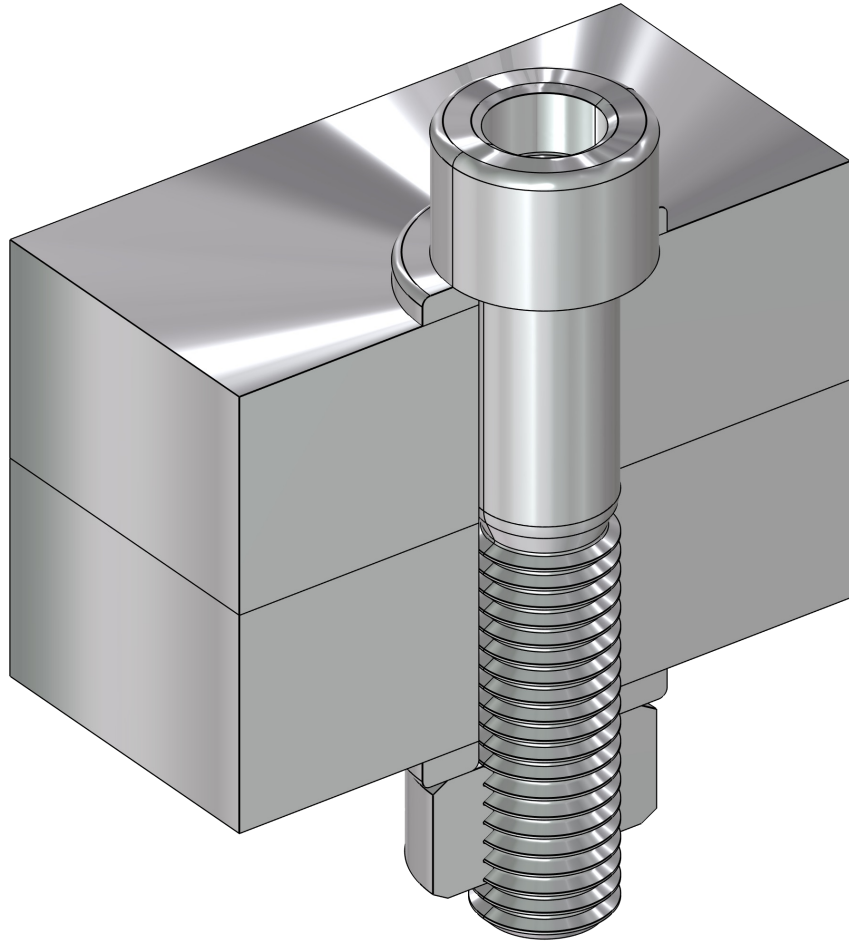

**3D – CAD – assembly as the basis for the simulation
(system partially in halved view to be able to see the screw)**

- An assembly of a 2D-axisymmetric bolt similar to a Hexagon socket screw has been constructed, which is per se more similar to a 2D axisymmetric shape than a hexagon head bolt.
- The M12 × 60 mm screw is mounted in a through hole with a diameter of $\varnothing_{\text{hole}} = 13 \text{ mm}$.
- This assembly contains besides the screw one nut, two washers and two blocks of metal (see Fig. I.).
- In the simulation, a vertical sectional view of this assembly has been used as geometric basis for the simulation.

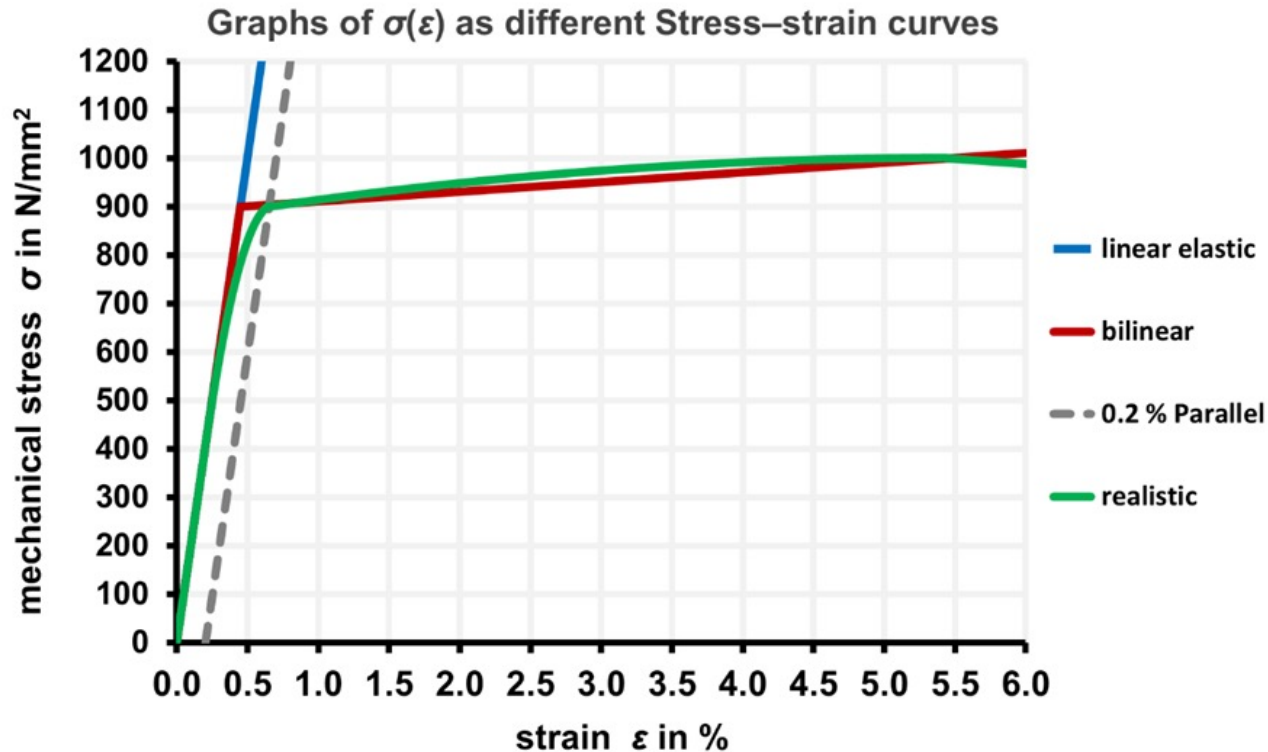
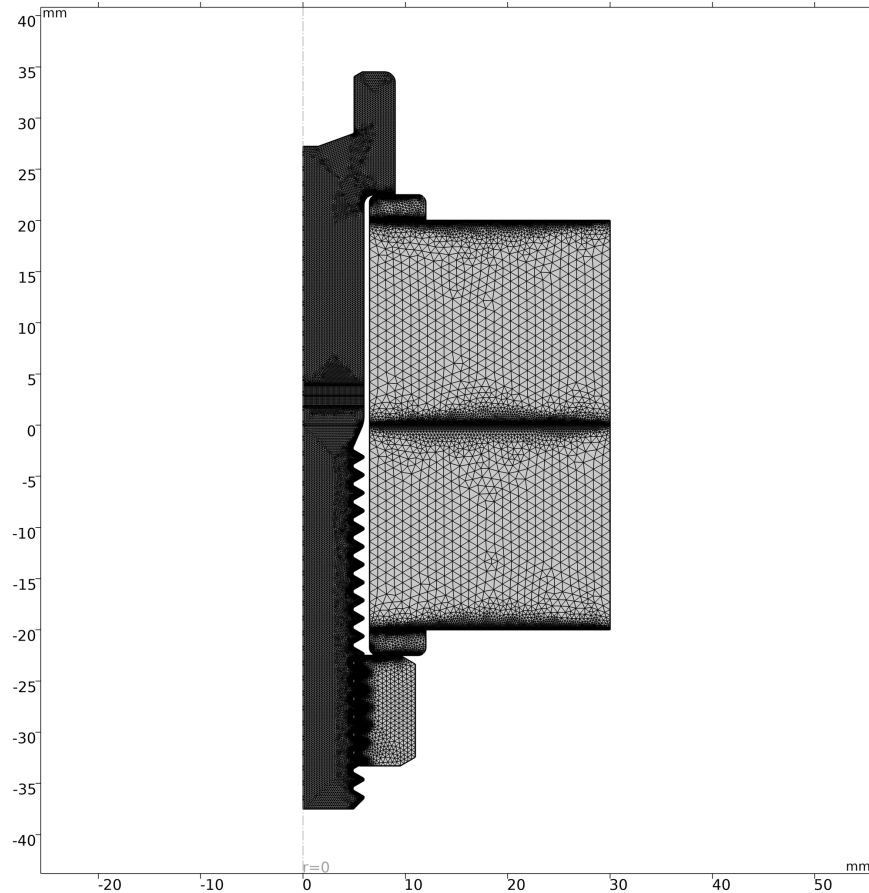

Diagram with different stress-strain-curves

- A bolt with steel as material and a strength class of 10.9 has been considered. That means, that the ultimate tensile strength (UTS) has a value of $R_m = 1000 \text{ N/mm}^2$. The 0.2 % yield strength is 90 % of this value, i. e. $R_{p0.2} = 900 \text{ N/mm}^2$. The Young's modulus is $E = 2 \cdot 10^5 \text{ N/mm}^2 = 200 \text{ GPa}$. The Poisson's ratio is $\nu = 0.3$. The density is $\rho = 7850 \text{ kg/m}^3$.

- Linear elastic simulations follow the simple equation $\sigma(\varepsilon) = E \cdot \varepsilon$. The mechanical stress σ increases linearly as function of the strain ε , if the Young's modulus E is constant and this is the case for linear elastic studies.
- Here in this work, it is simulated materially nonlinearly and some studies are additionally calculated in linear elastic for comparison.
- A value of the so-called isotropic tangent modulus of $E_T = 2 \text{ GPa} = 0.01 \cdot E$ is present here. This is the slope of the bi-linear model of the stress-strain curve in the plastic range. This slope is by 99 % lower than the Young's modulus.
- $\sigma_{\text{linearelastic}}(\varepsilon = 1 \%) = 2000 \text{ N/mm}^2$ (much too high)
- $\sigma_{\text{bilinear}}(\varepsilon = 1 \%) = 911 \text{ N/mm}^2$ (realistic)
- For example, a strain of $\varepsilon = 1 \%$ is present when a stress of 911 N/mm^2 is reached in the bilinear model. For the same strain, the linear elastic model leads to a stress of 2000 N/mm^2 which is much too high compared to reality. For larger strains the relative deviations are even larger.

Finite Element Mesh (FE-Mesh) with tetrahedral elements



**Total view of a very fine tetrahedral FE-mesh
with in total $n = 0.138277$ Mio. elements**

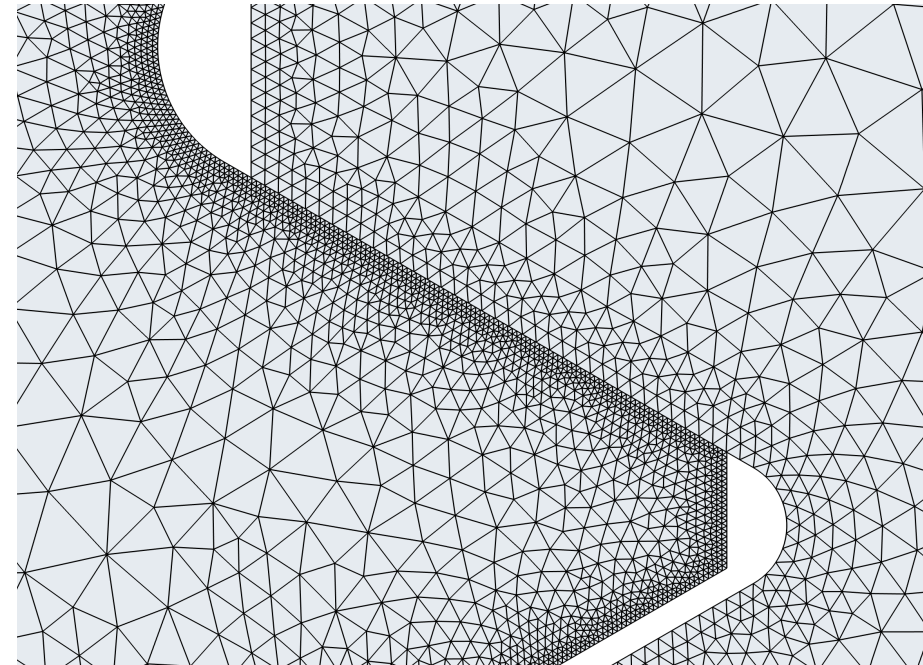

**Zoom-In: Part of the tetrahedral
FE-Mesh at one thread flank**

**Hints of COMSOL for the FE-Meshing
to the topic of mechanical contact:**

<https://www.comsol.de/support/knowledgebase/1102>

- The side length of the tetrahedral finite elements at the threads has been set to a value of $\Delta s = 10 \mu\text{m}$.
The contact length at each thread has a value of $\Delta l \approx 1036 \mu\text{m}$, thus a number of about 104 elements can be placed there.

Alternative Finite Element Mesh (FE-Mesh) with only quadrilateral elements

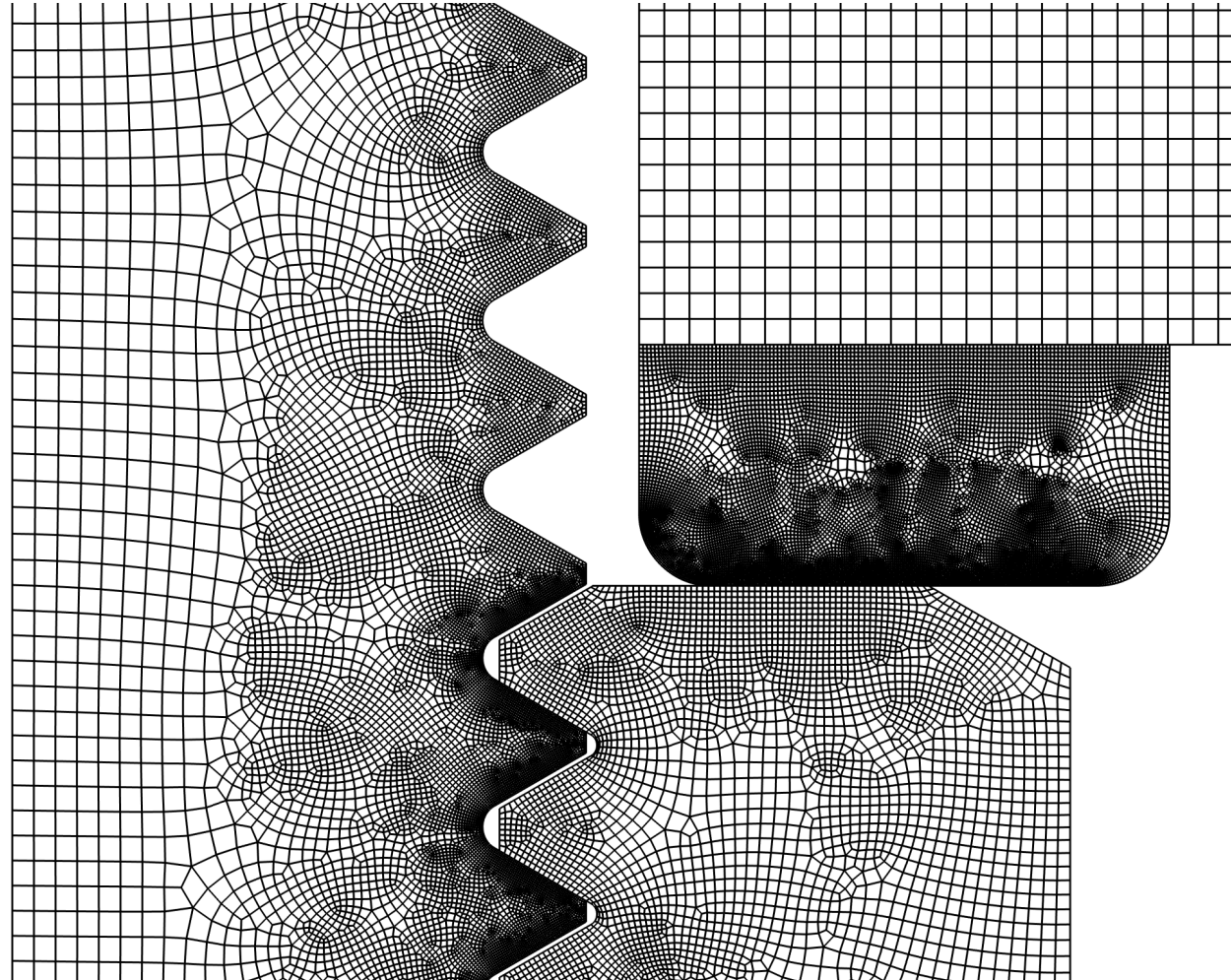

- The side length of these quadrilateral finite elements at the threads has been set to a value of $\Delta s = 20 \mu\text{m}$.

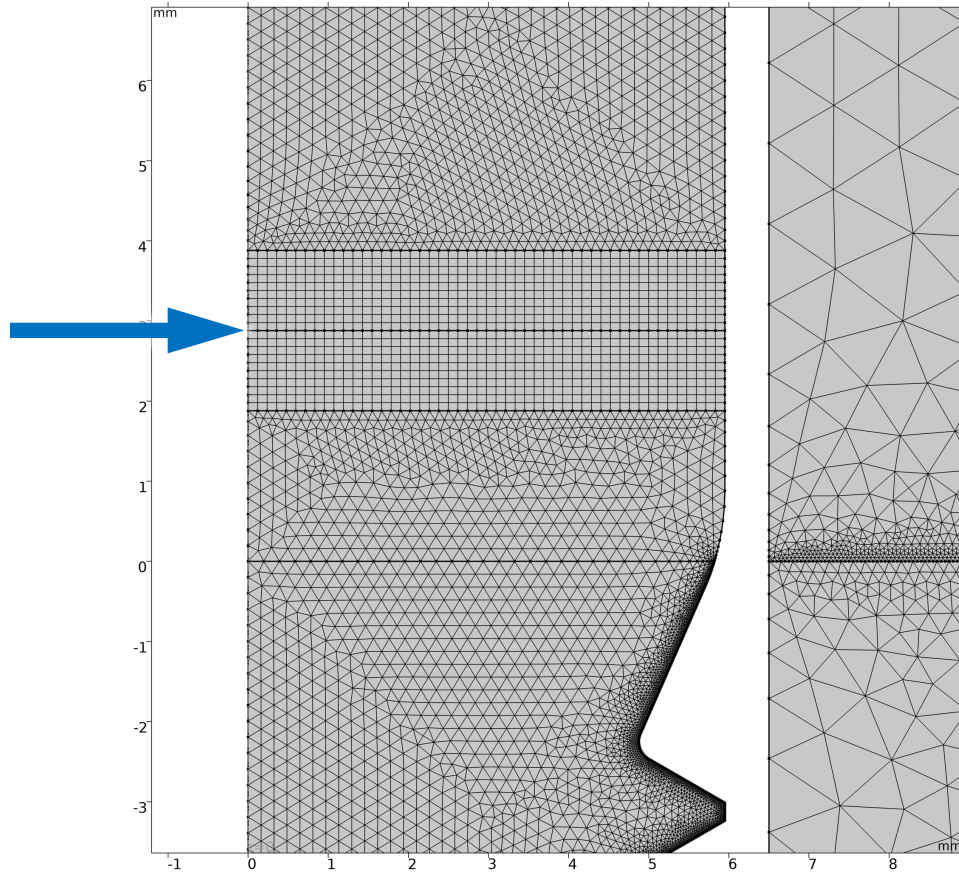

**Part of the FE-mesh
around the middle of the screw**

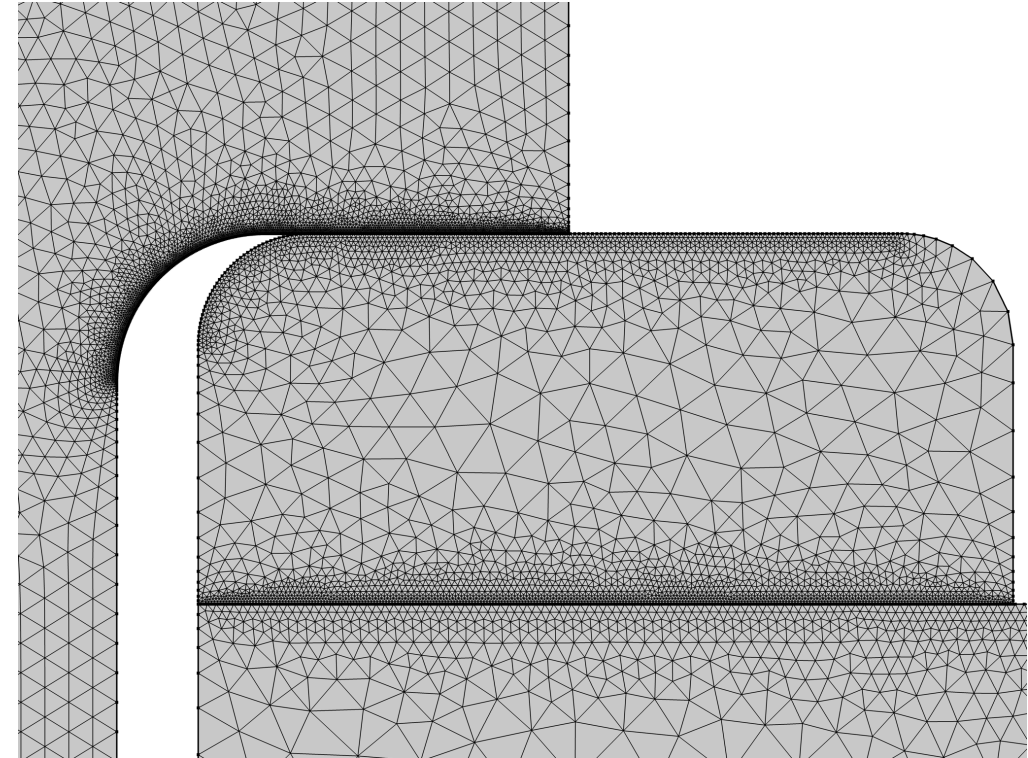

**Part of the FE-mesh
at the head of the screw and the upper washer**

- The **blue arrow** marks the plane or line of inducing the prestressing force. Rectangles have been used as very structured finite elements around this line to stabilize the simulation especially at the beginning of ramping up the preload.

Overview of the whole system: equivalent stress according to von Mises

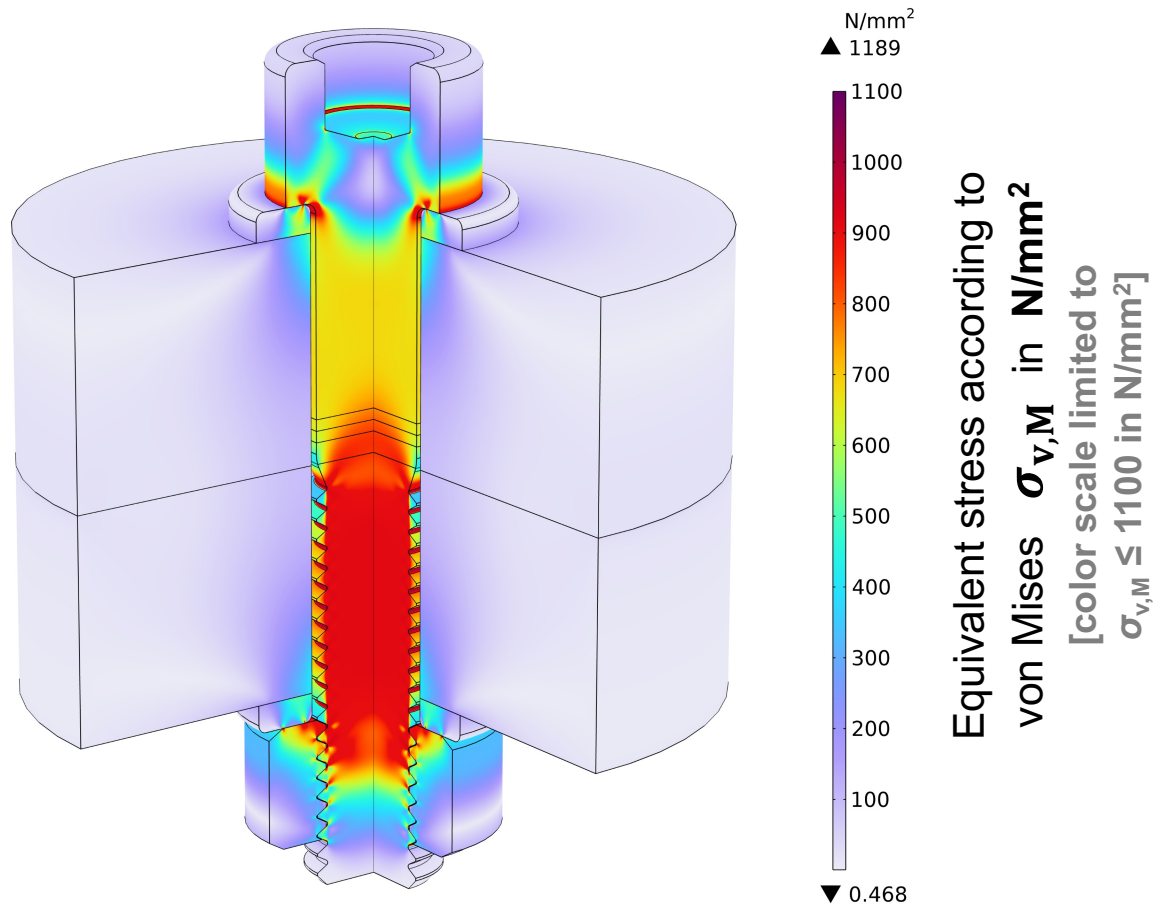

- Several areas of the simulated geometry are of interest for a detailed presentation.
- An overview of the entire geometry of the nonlinear study for a high preload force with representation of the equivalent stress according to von Mises is displayed in the Fig. left.
- Large stresses can be seen in the area of the thread and in the area of the transition of the bolt to the screw head.
- Certain areas, such as the thread contact between the screw and the nut, are particularly interesting and will be shown in more detail in the following.

Nonlinear calculation; $F_{\text{preload}} = 75 \text{ kN}$; simulation result spanned by $\varphi = 270^\circ$ with display of the equivalent stress according to von Mises (color scale limited to $\sigma_v \leq 1100 \text{ N/mm}^2$ for direct comparability to other simulation results in the following) [fine tetrahedral mesh]

Area around screw & nut: equivalent stress according to von Mises

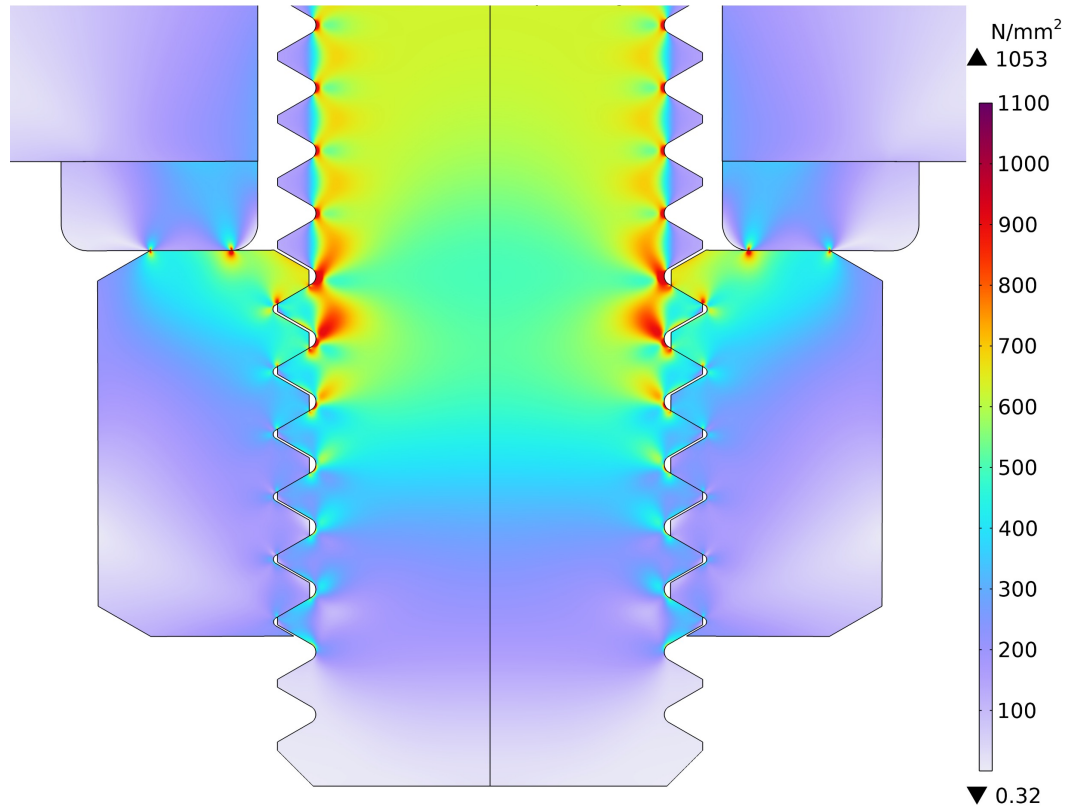

Equivalent stress according to von Mises $\sigma_{v,M}$ in N/mm²

**Nonlinear calculation; $F_{\text{preload}} = 50$ kN;
equivalent stress according to von Mises [fine tetrahedral mesh]**

- In the figure left, the equivalent stress is displayed for a preload of $F_{\text{preload}} = 50$ kN.
- In the area of the first thread, the highest stresses occur in the rounded transitions to the other threads.
- The max. stress occurs in the upper fillet of the first thread and has a value of $\sigma_v \approx 929 \text{ N/mm}^2 > R_{p0.2}$, so this mechanical load is locally already in the plastic range.
- For direct comparability to most of the following simulation results, the color scale is limited to $\sigma_{v,M} \leq 1100$ in N/mm².

Nonlinear calculation in comparison to linear elastic calculation

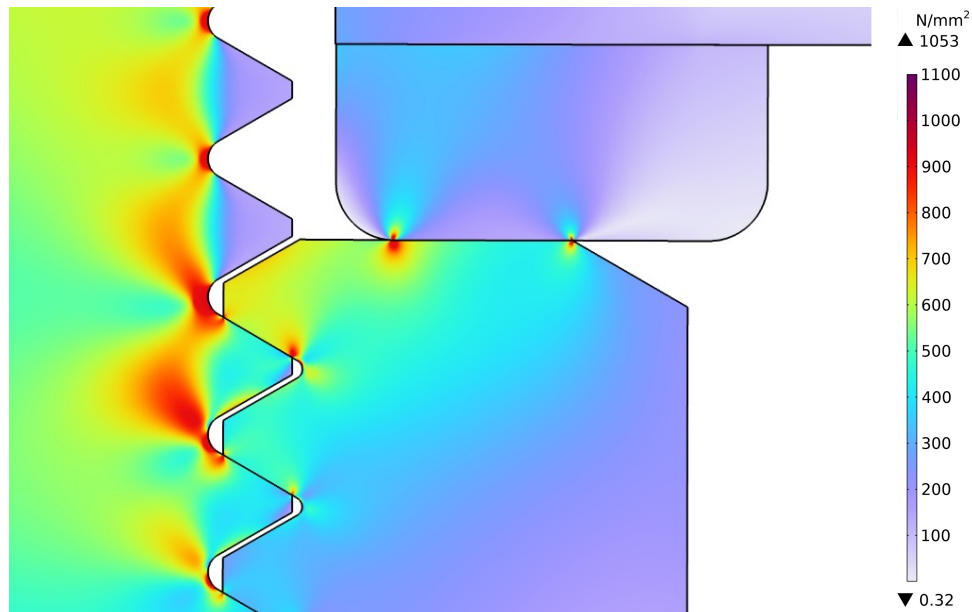

Nonlinear calculation; $F_{\text{preload}} = 50 \text{ kN}$;

$$\sigma_{v,\text{max}} \approx 929 \text{ N/mm}^2$$

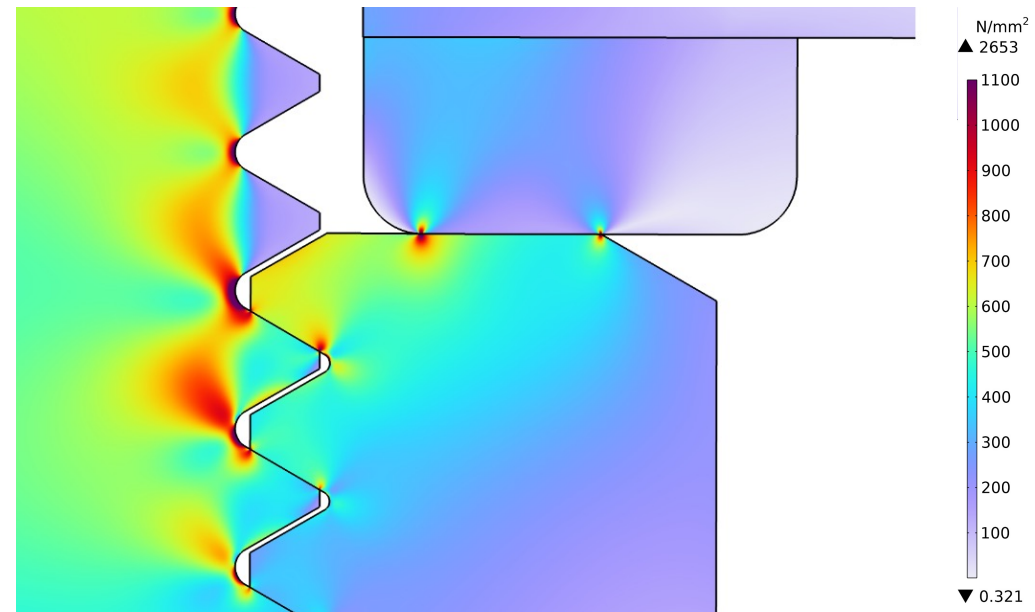

Linear elastic calculation; $F_{\text{preload}} = 50 \text{ kN}$;

$$\begin{aligned} \sigma_{v,\text{max}} &\approx 2330 \text{ N/mm}^2 \\ &\approx 2.51 \cdot 929 \text{ N/mm}^2 \end{aligned}$$

Equivalent stress according to
von Mises $\sigma_{v,M}$ in N/mm^2

- The max. stresses occurring in the upper fillet of the first thread in each case are compared here.
- For direct comparability of these and to most of the following simulation results, the color scale is limited to $\sigma_{v,M} \leq 1100 \text{ in N/mm}^2$.

Nonlinear calculation for 50 kN (l.) and 75 kN (r.)

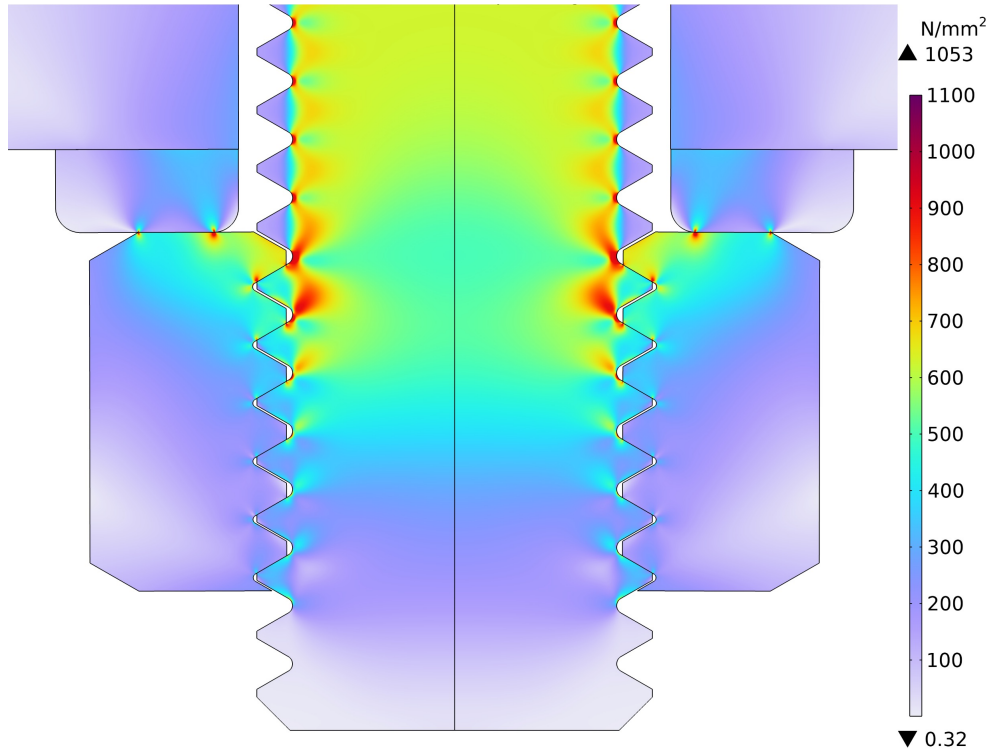

Nonlinear calculation; $F_{\text{preload}} = 50 \text{ kN}$;
equivalent stress according to von Mises

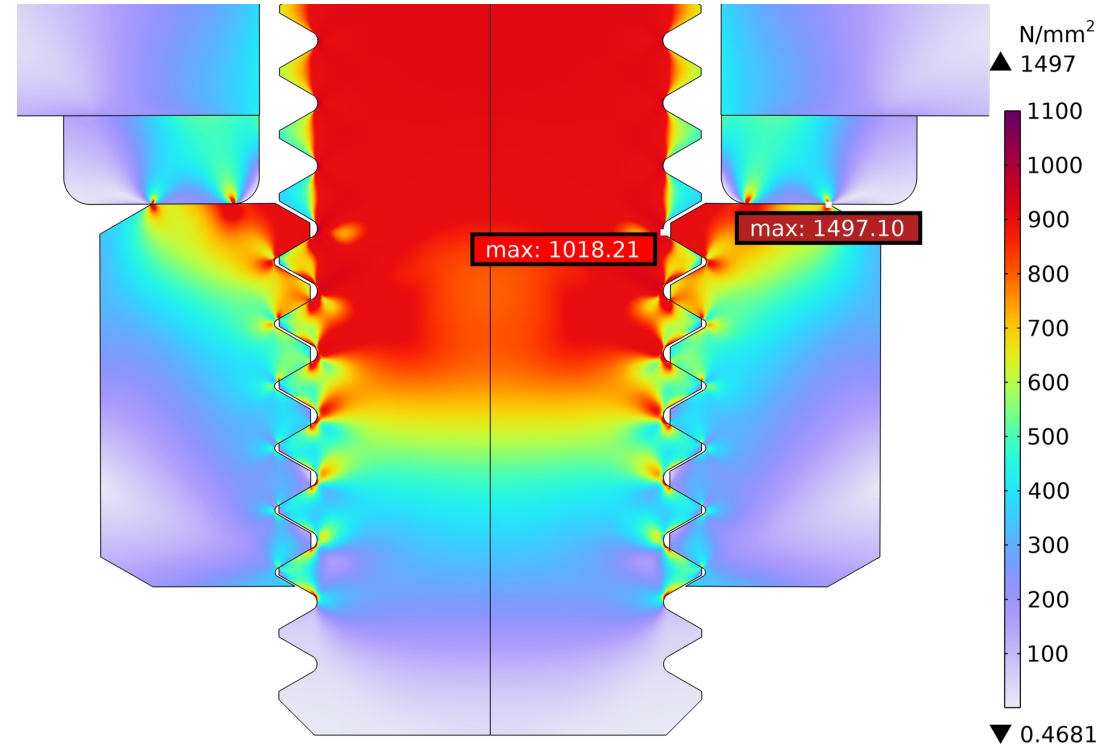

Nonlinear calculation; $F_{\text{preload}} = 75 \text{ kN}$;
equivalent stress according to von Mises

Equivalent stress according to
von Mises $\sigma_{v,M}$ in N/mm²

Nonlinear (l.) & linear elastic (r.) calculation in comparison for $F_{\text{preload}} = 75 \text{ kN}$

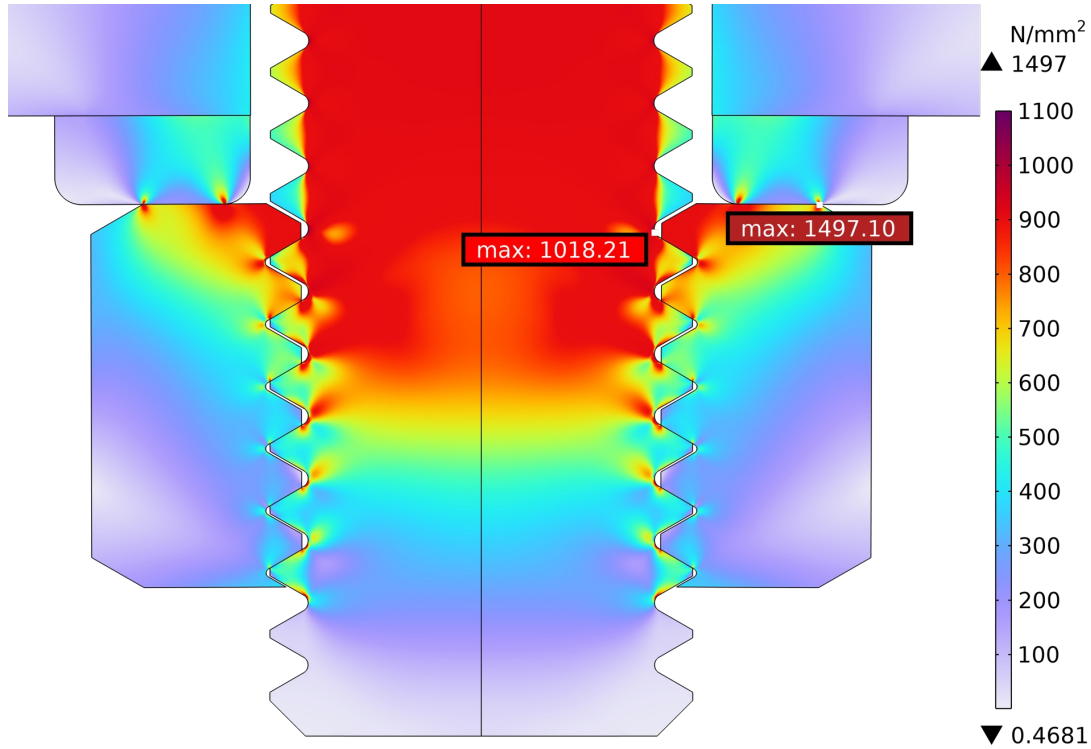

Nonlinear calculation; $F_{\text{preload}} = 75 \text{ kN}$;

$\sigma_{v,\text{max}} \approx 1018.21 \text{ N/mm}^2$

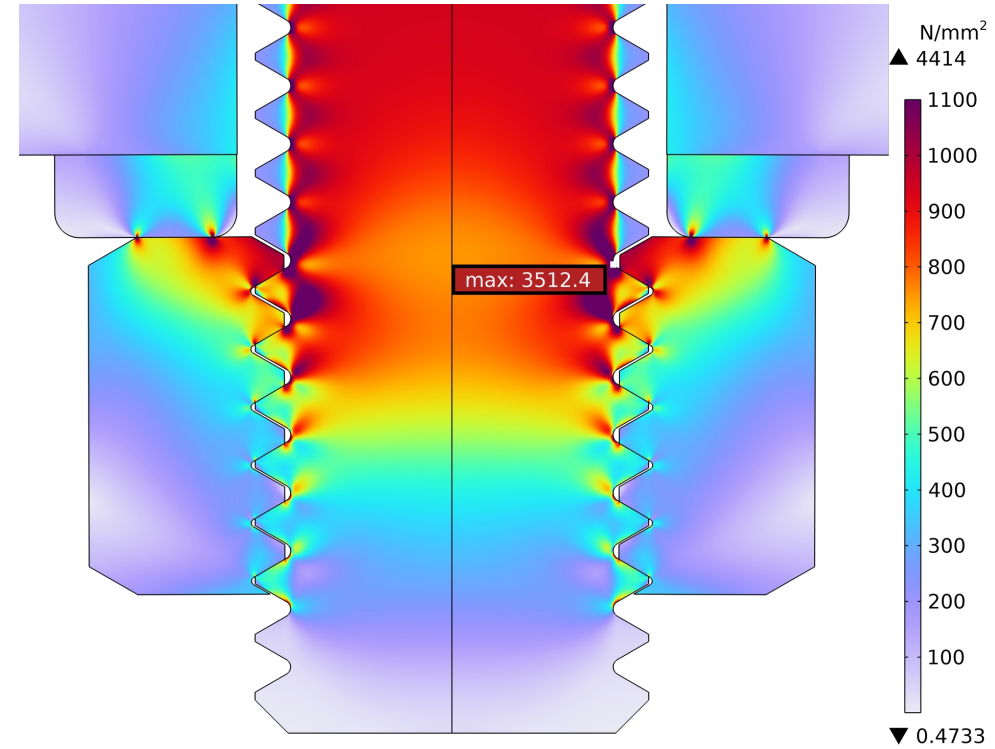

Linear elastic calculation; $F_{\text{preload}} = 75 \text{ kN}$;

$\sigma_{v,\text{max}} \approx 3512.4 \text{ N/mm}^2$
 $\approx 3.45 \cdot 1018.21 \text{ N/mm}^2$

Equivalent stress according to
von Mises $\sigma_{v,M}$ in N/mm^2

- The strong notch effect or stress concentration in some areas is only to see in the linear elastic result because of the onset of plastification in the nonlinear model for this very high preload.

Linear elastic calculations incl. root radii (l.) and without them (r.) for 75 kN

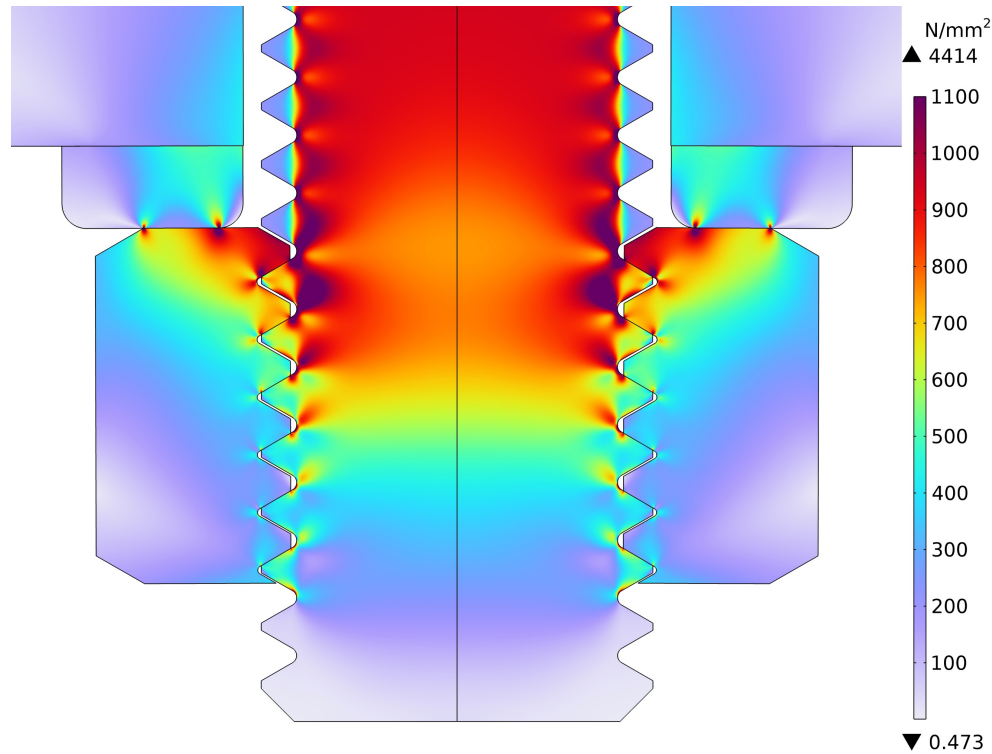

Linear elastic calculation; $F_{\text{preload}} = 75 \text{ kN}$;
including root radii resp. core fillets

$$\sigma_{v,\text{max}} \approx 3512.4 \text{ N/mm}^2$$

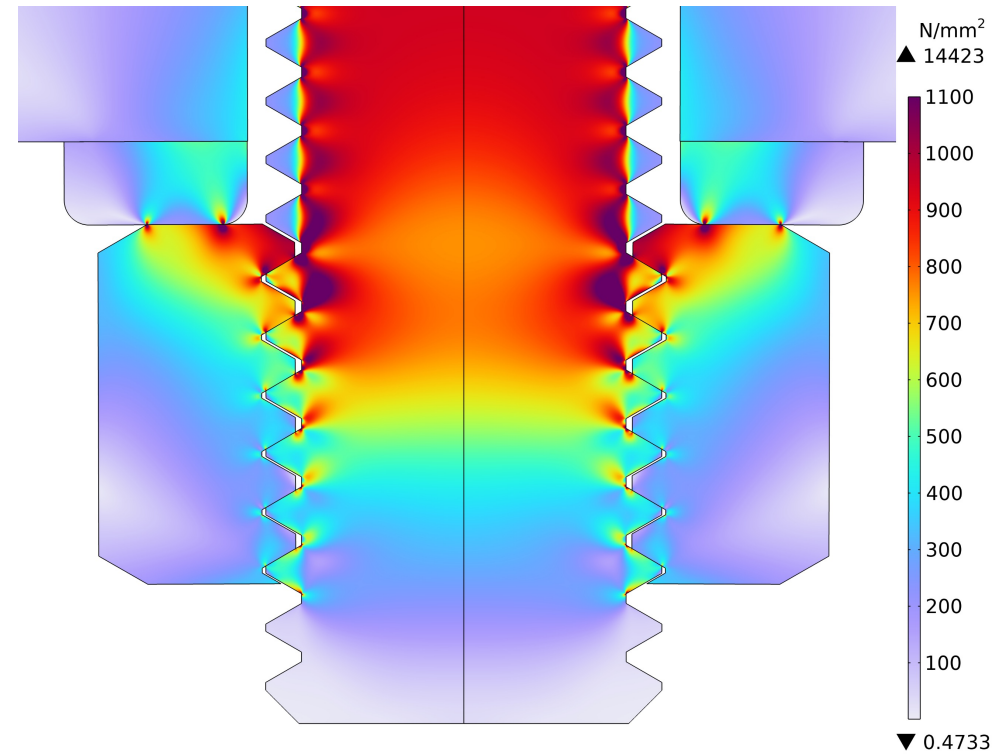

Linear elastic calculation; $F_{\text{preload}} = 75 \text{ kN}$;
excluding root radii resp. core fillets

$$\sigma_{v,\text{max}} \approx 14423 \text{ N/mm}^2 \\ \approx 4.11 \cdot 3512.4 \text{ N/mm}^2$$

Equivalent stress according to
von Mises $\sigma_{v,M}$ in N/mm²

- The max. stresses occurring in the upper fillet of the first thread in each case are compared here.

Linear elastic calculation exclusive root radii for $F_{\text{preload}} = 75 \text{ kN}$

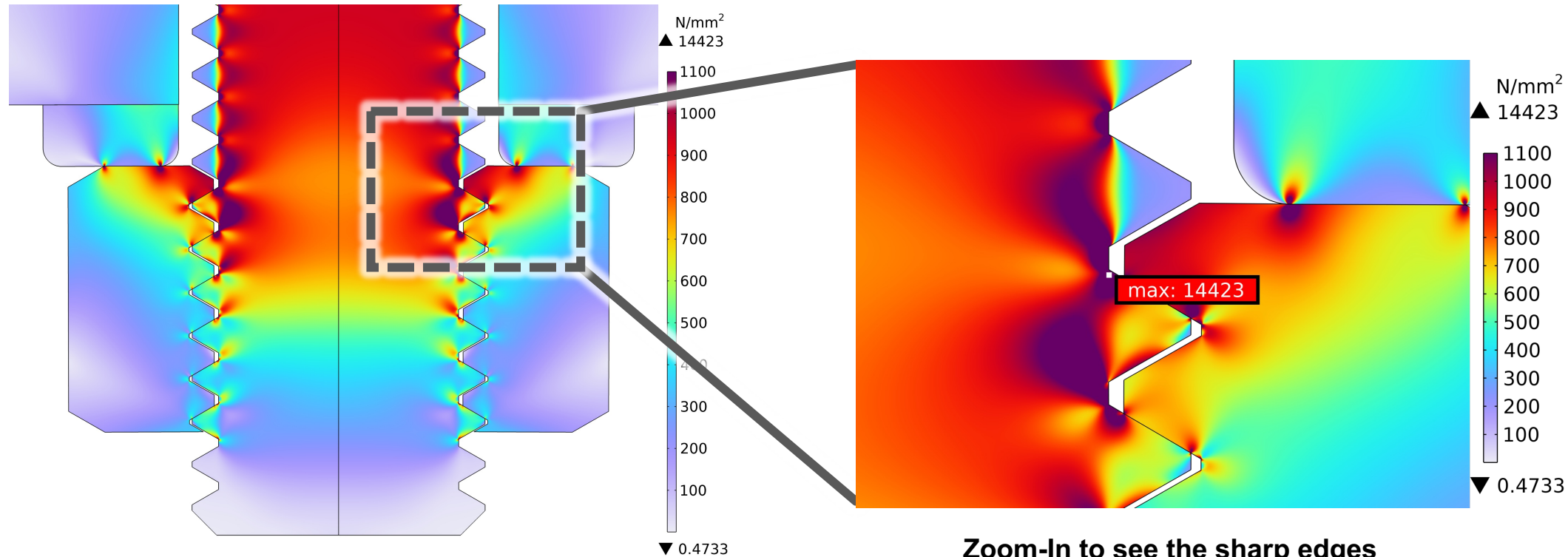

Equivalent stress according to von Mises $\sigma_{v,M}$ in N/mm^2

Linear elastic calculation; $F_{\text{preload}} = 75 \text{ kN}$; including root radii resp. core fillets

Zoom-In to see the sharp edges with marking of the maximal stress

- Locally concentrated, very high stress peaks are to see here because of a very strong notch effect due to very sharp geometric transitions.

Table for comparison

	Preload of $F_{\text{preload}} = 50 \text{ kN}$		Preload of $F_{\text{preload}} = 75 \text{ kN}$	
materially or physically nonlinear incl. root radii	929 N/mm ²	± 0 %	1018 N/mm ²	± 0 %
Linear elastic with $E = \text{const.}$ incl. root radii	2330 N/mm ²	+ 151 %	3512 N/mm ²	+ 245 %
Linear elastic <u>excl.</u> root radii (geometrically simplified)	9360 N/mm ²	+ 908 %	14423 N/mm ²	+ 1317 %

Table of the maximal stresses according to von Mises $\sigma_{v,M}$ in N/mm²
occurring in the upper fillet of the first thread
[relative comparison in each case for the same preload force (for the same column)]

FE-mesh comparison study with the same type of mesh

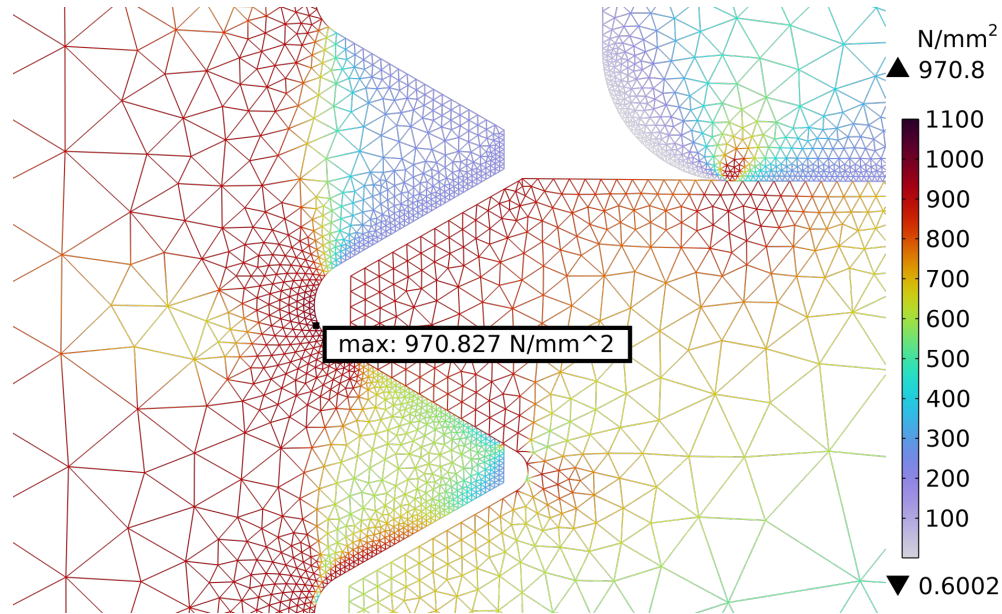

**Nonlinear calculation; $F_{\text{preload}} = 70$ kN;
equivalent stress according to von Mises;
[coarser tetrahedral mesh]**

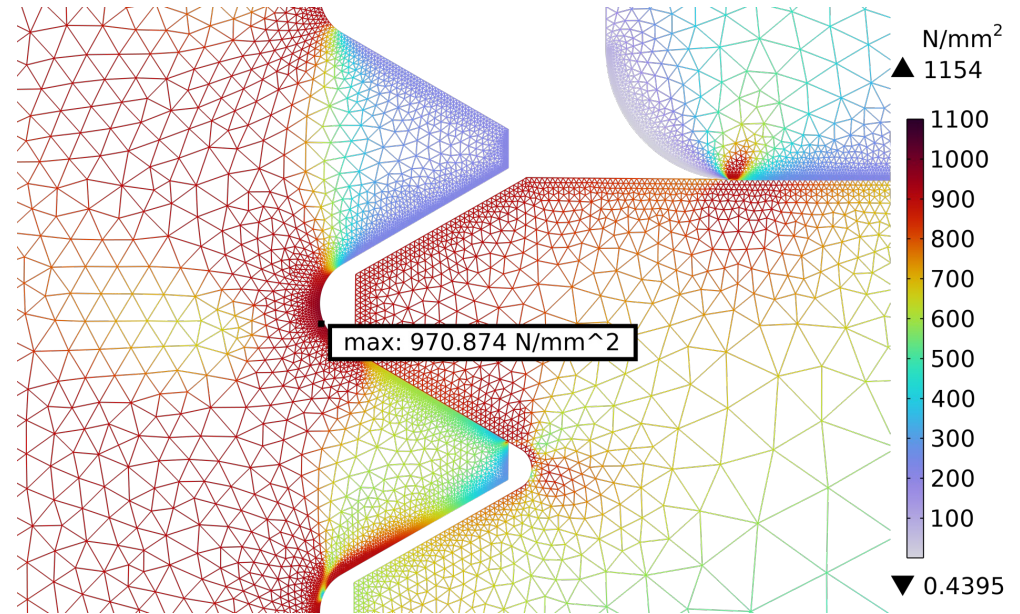

**Nonlinear calculation; $F_{\text{preload}} = 70$ kN;
equivalent stress according to von Mises;
[fine tetrahedral mesh]**

Equivalent stress according to
von Mises $\sigma_{v,M}$ in N/mm²

- The relative deviation of the max. stresses occurring in the upper fillet of the first thread in each case calculated for these meshes is approximately 0.05 ‰ because of $(970.874 / 970.827) \approx 1.000048$. The coarser tetrahedral mesh seems to be fine enough for accurate results, too.

FE-mesh comparison study with different types of mesh

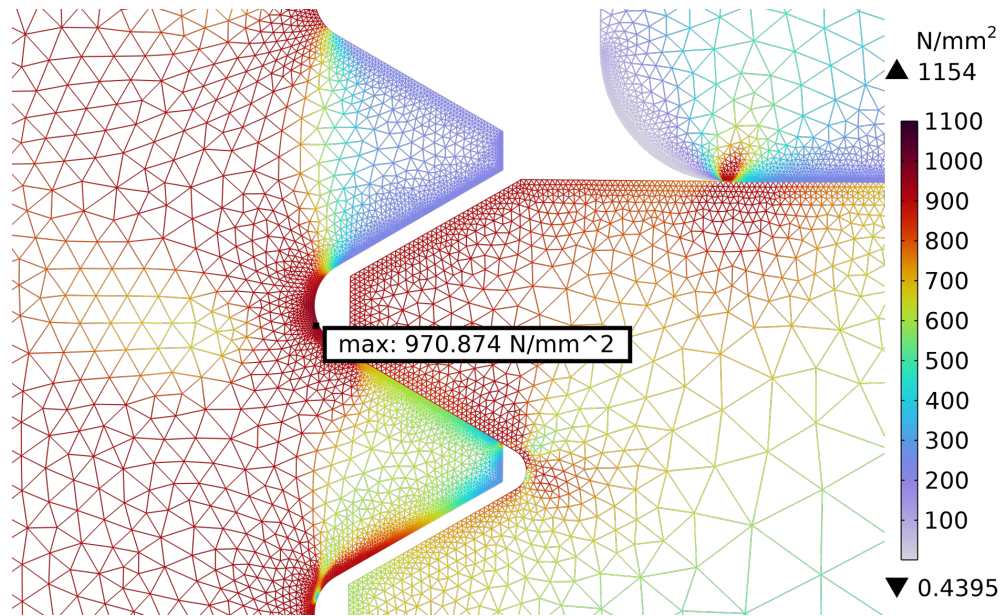

**Nonlinear calculation; $F_{\text{preload}} = 70 \text{ kN}$;
equivalent stress according to von Mises;
[fine tetrahedral mesh]**

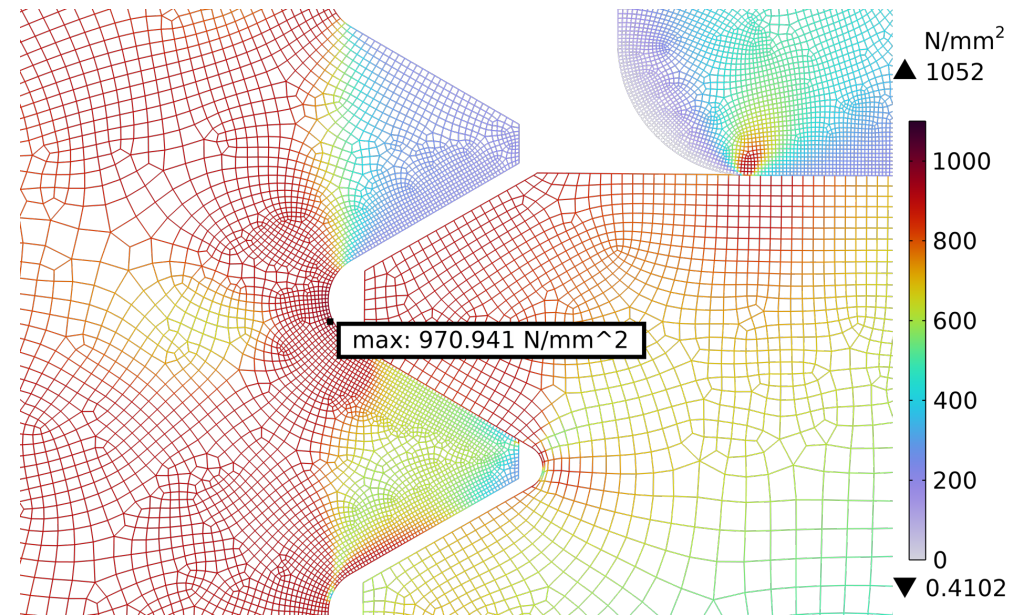

**Nonlinear calculation; $F_{\text{preload}} = 70 \text{ kN}$;
equivalent stress according to von Mises;
[quadrilateral mesh]**

Equivalent stress according to
von Mises $\sigma_{v,M}$ in N/mm^2

- The relative deviation of the max. stresses occurring in the upper fillet of the first thread in each case calculated for these meshes is approximately 0.07 ‰ because of $(970.941 / 970.874) \approx 1.000069$.
- A quadrilateral mesh in general is a more structured mesh, whereas especially with complicated details of a 3D geometry tetrahedral elements often enable a more easily meshing.

Area around the screw head: stress (von Mises) & contact pressure

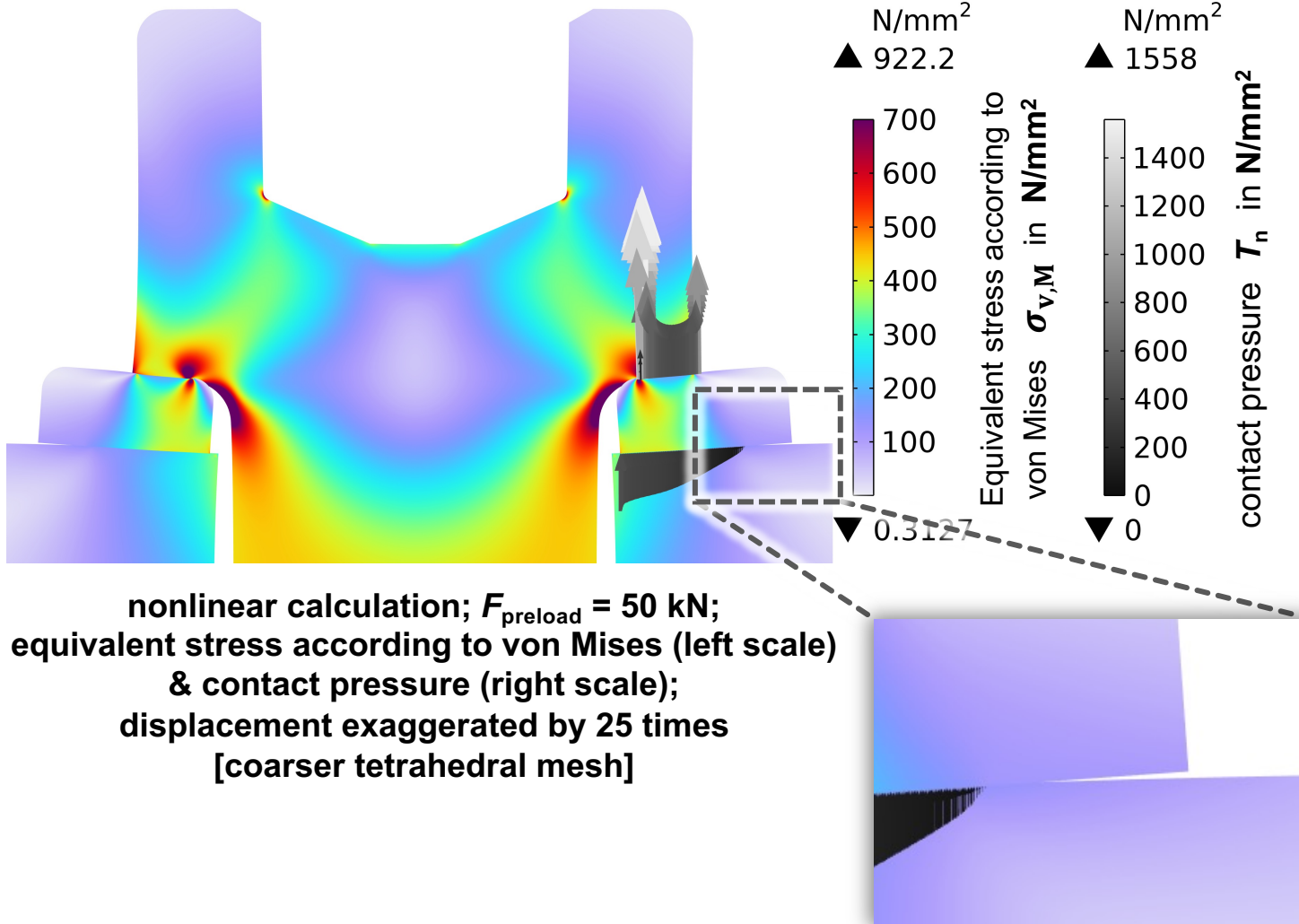

- In the fillet of the transition from the bolt to the screw head, a strong notch effect also occurs here (radius modeled with $r = 1 \text{ mm}$).
- At the edges of the screw head contact surface, there is a strong contact pressure increase radially inwards and outwards. The high surface pressures would damage, notch or scratch the contact surface.
- The washer with a contact surface that is larger by a factor of ≈ 3.58 significantly reduces the contact pressure and thus fulfills its purpose of not damaging the component.
- Surprisingly, the radially outer region of the washer lifts off the bearing or contact surface, resulting in zero contact pressure over a fairly large area. Analytical calculations would only provide the average values without detecting the extreme distribution.
- The maximal gap distance between the outer diameter of the washer to the metal block is $\Delta z_{\text{gap}} = 2.134 \mu\text{m}$ for a preload of $F_{\text{preload}} = 50 \text{ kN}$.

Overview: contact pressure at the threads

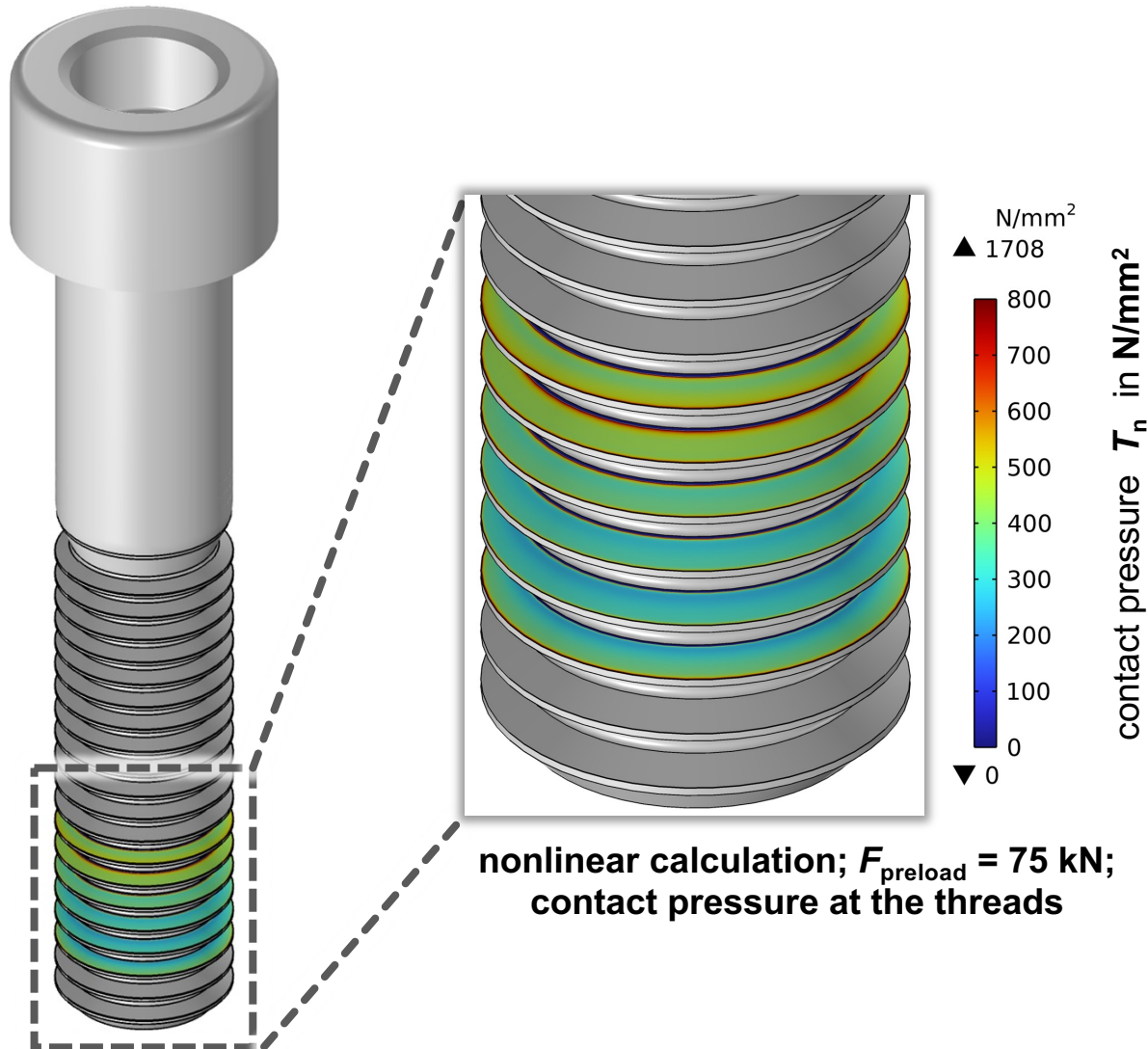

- Nonlinear calculation; $F_{\text{preload}} = 75 \text{ kN}$;
- simulation result spanned by $\varphi = 360^\circ$ with display of the contact pressure (color scale limited to $T_n \leq 800 \text{ N/mm}^2$ for better readability)
- This illustration provides an overview of the contact pressure at the threads.
- The contact pressure at the threads is shown in more detail for different preloads in the following.

Contact pressure at the threads (nonlinear simulation)

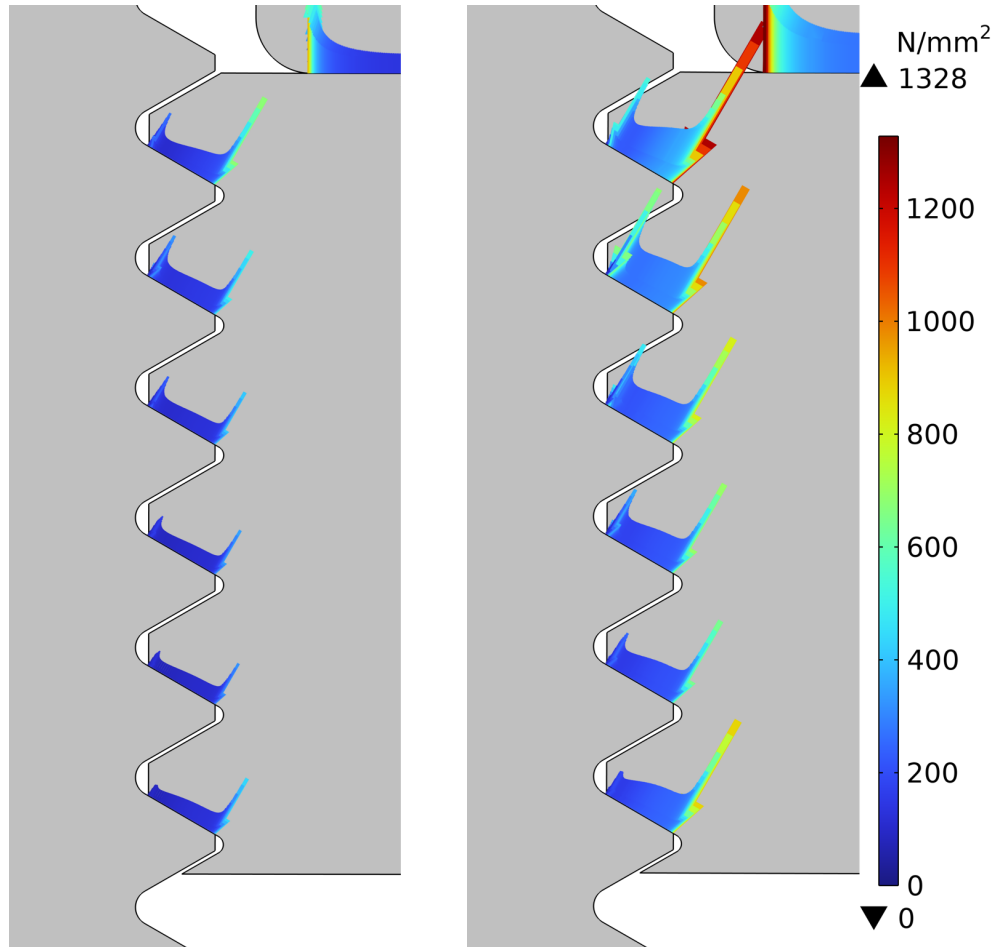

$F_{\text{preload}} = 25 \text{ kN}$

$F_{\text{preload}} = 50 \text{ kN}$

contact pressure T_n in N/mm^2

- At the points where the contact lines end there occur strong pressure peaks.
- The load share of the 1st thread is:
 $\varphi_1 = 21.4 \%$ (for 25 kN)
 $\varphi_1 = 21.1 \%$ (for 50 kN)
- Surprisingly, the average contact pressure or load on the last (6th) thread is greater than that of the penultimate (5th) thread.

Contact pressure at the threads (nonlinear simulation, very high preloads)

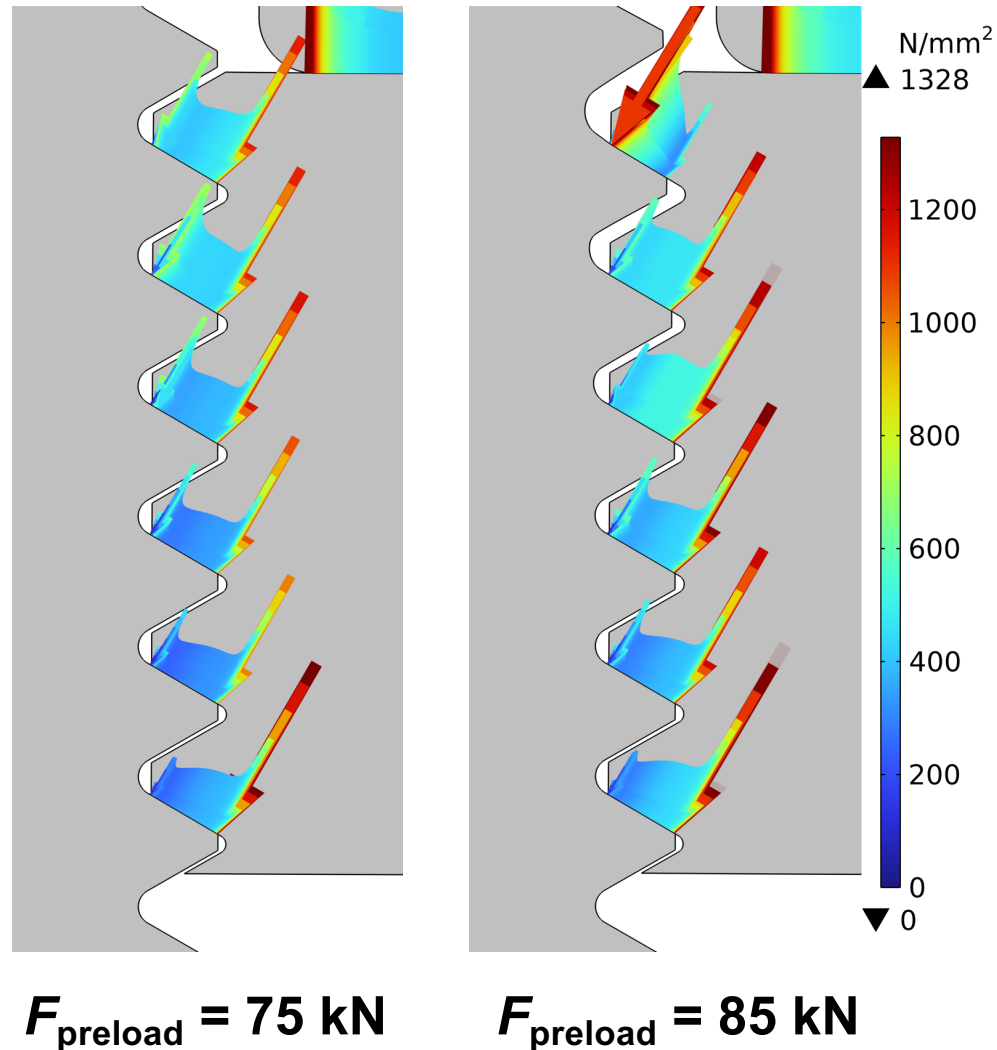

contact pressure T_n in N/mm²

- At the points where the contact lines end there occur strong pressure peaks here, too.
- The load share of the 1st thread is:
 $\varphi_1 = 19.4 \%$ (for 75 kN)
 $\varphi_1 = 18.1 \%$ (for 85 kN)
- The preload of $F_{\text{preload}} = 85 \text{ kN}$ is too high. The screw would have failed mechanically before reaching this extreme preload force, but this result could be determined by simulation.
- For this preload of 85 kN the load distribution does not lead to perfectly balanced load shares of $\varphi_i = 1/6 \approx 16.67 \%$.
- In the second figure it can be seen that the displacement is so large that the distance between the first two threads of the bolt and the internal thread of the nut significantly increases. The displacement has been set realistically with a deformation scaling factor of '1'.

Table for the load shares (nonlinear simulation)

	Load shares of the individual threads (The 1 st thread is the top one in the last figures)					
F_{preload} in kN	1st	2nd	3rd	4th	5th	6th
25	21.4 %	20.5 %	16.5 %	13.9 %	12.8 %	14.9 %
50	21.1 %	20.5 %	16.6 %	14.0 %	12.9 %	15.0 %
75	19.4 %	19.9 %	17.1 %	14.6 %	13.5 %	15.5 %
85	18.1 %	16.9 %	18.9 %	15.9 %	14.2 %	16.0 %

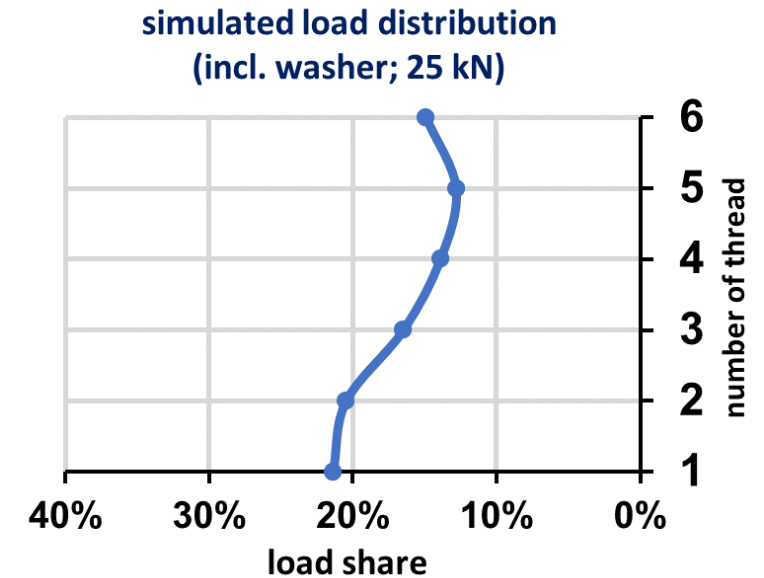

Load distribution for different pretensions
(coarser tetrahedral mesh)

Contact pressure at the threads (steel in comparison to aluminum)

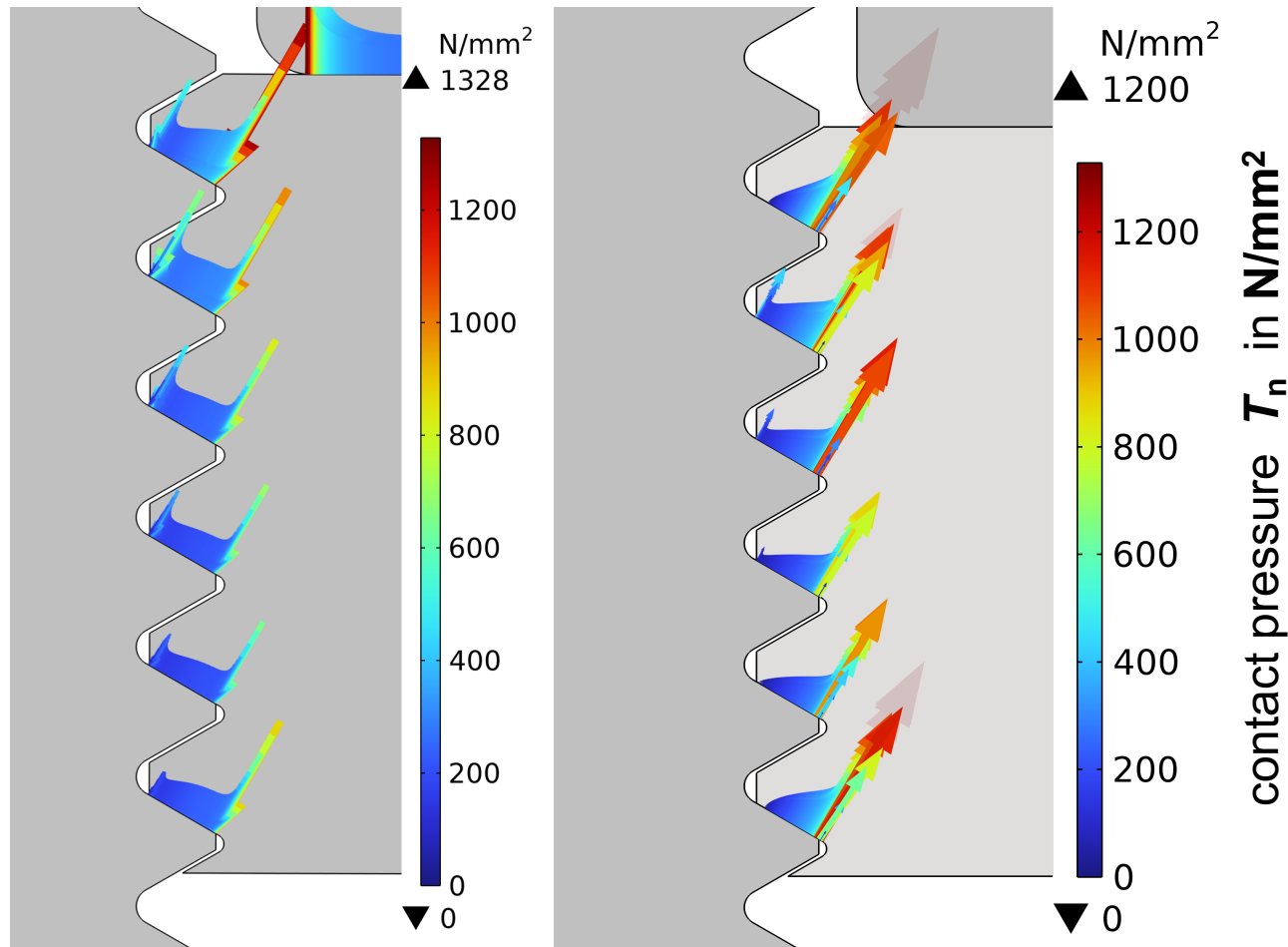

**nut in steel
(as before)**

nut in aluminum

contact pressure T_n in N/mm²

- Simulations results for a preload of 50 kN
- The load share of the 1st thread is:
 $\varphi_{1,\text{steel}} = 21.1\%$ (steel, for 50 kN)
 $\varphi_{1,\text{Alu}} = 17.7\%$ (aluminum, for 50 kN)
- Aluminum is mechanically softer than steel and that is the reason for a more homogenous load distribution.
 $E_{\text{Alu}} = 70 \text{ GPa} = 0.35 \cdot E_{\text{steel}}$
 $\rho_{\text{Alu}} = 2700 \text{ kg/m}^3 \approx 0.34 \cdot \rho_{\text{steel}}$
- The profile of the contact pressure has another shape almost similar to a triangular shape using aluminum as mechanically softer metal for the nut.

Contact pressure at the threads (nonlinear simulation)

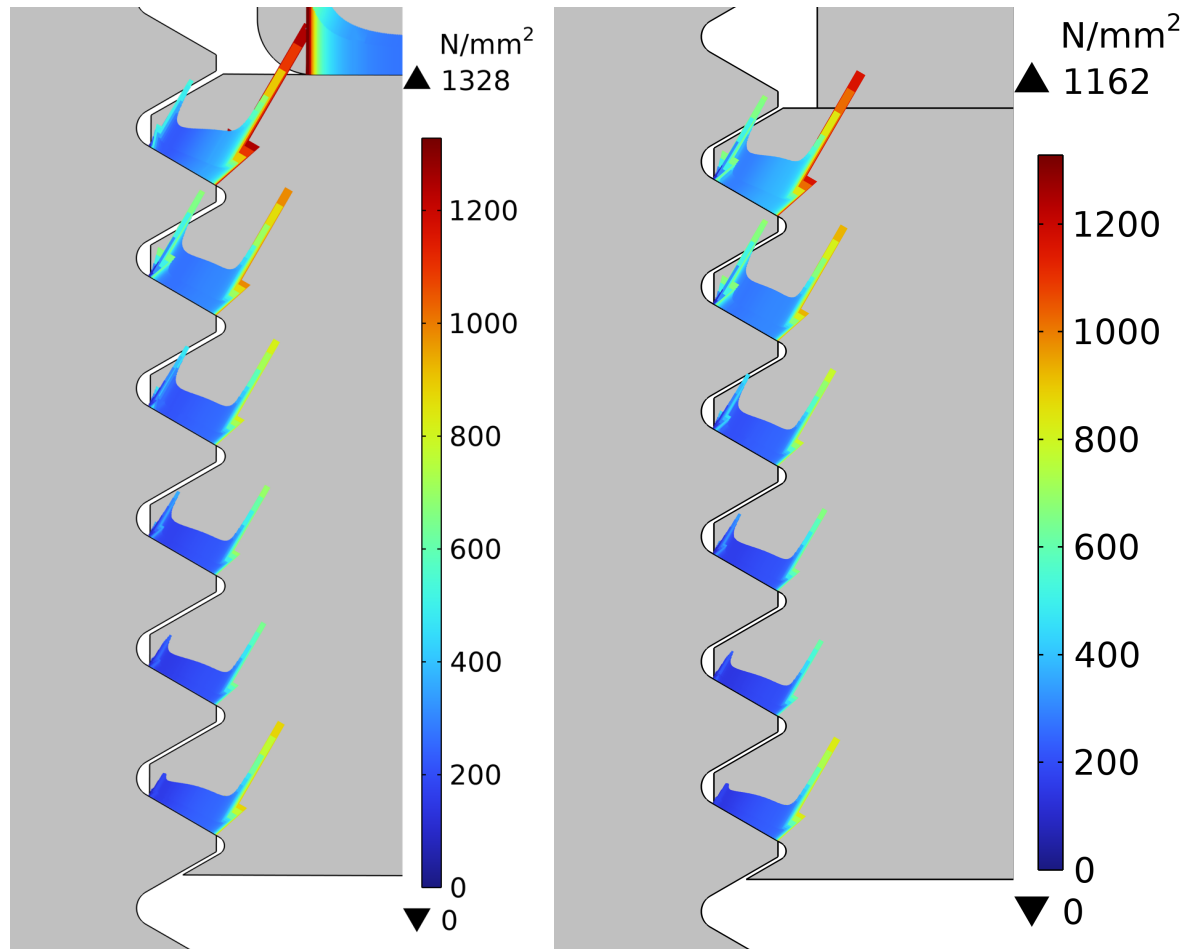

**incl. washer
at the nut**

**without washer
at the nut**

contact pressure T_n in N/mm²

- Simulations results for a preload of 50 kN and steel as material
- An additional simulation was carried out with omission of the washer at the nut. This study showed a larger load share of the first thread of $\varphi_1 = 23.9 \%$. This can be explained by the fact that the force flow without washer has to cover a shorter distance to the first thread, i. e. the force is applied more directly.

- The load share of the 1st thread is:

$$\varphi_1 = 21.1 \% \quad (\text{including washer})$$

$$\varphi_1 = 23.9 \% \quad (\text{excluding washer})$$

Contact pressure at the 1st thread (comparison of different details; 50 kN)

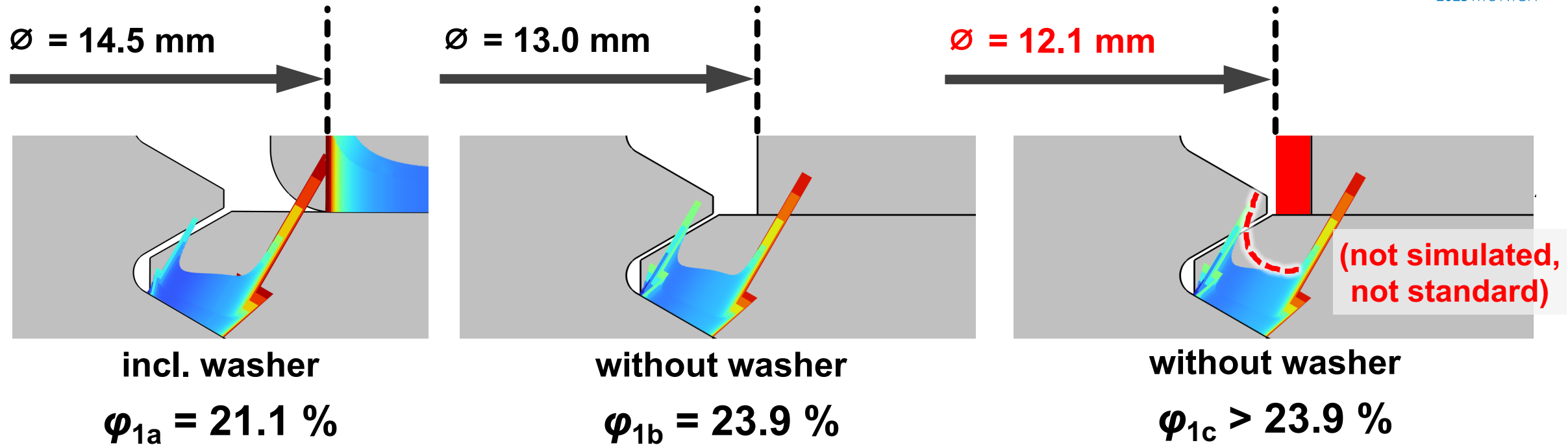

- The washer was designed with radii of $r = 0.75 \text{ mm}$. Concerning the effects on the load distribution, this seems to be similar to omit the washer and simultaneously to increase the through hole diameter to $\varnothing = (13 + 2 \cdot 0.75) \text{ mm} = 14.5 \text{ mm}$ (large standard value for M12).
- The through hole diameter chosen here in this work of $\varnothing = 13 \text{ mm}$ is a possible small standard value.
- In another FEM-work performed by Yang et. al. [2] the through hole diameter is modeled with $\varnothing = 12.1 \text{ mm}$ or 12 mm . This is not standard and they have calculated $\varphi^* \approx 28 \%$.
- This larger load share can be explained by the fact that the force flow with a smaller through hole diameter has to cover a shorter distance to the first thread, i. e. the force is applied more directly, so the force can flow even more directly with more radially inner contact surface.

source of [2]: G. Yang et. al., "Three-dimensional Finite Element Analysis of the Mechanical Properties of Helical Thread Connection", 2013.

Contact pressure at the 1st thread (comparison of different bore diameters)

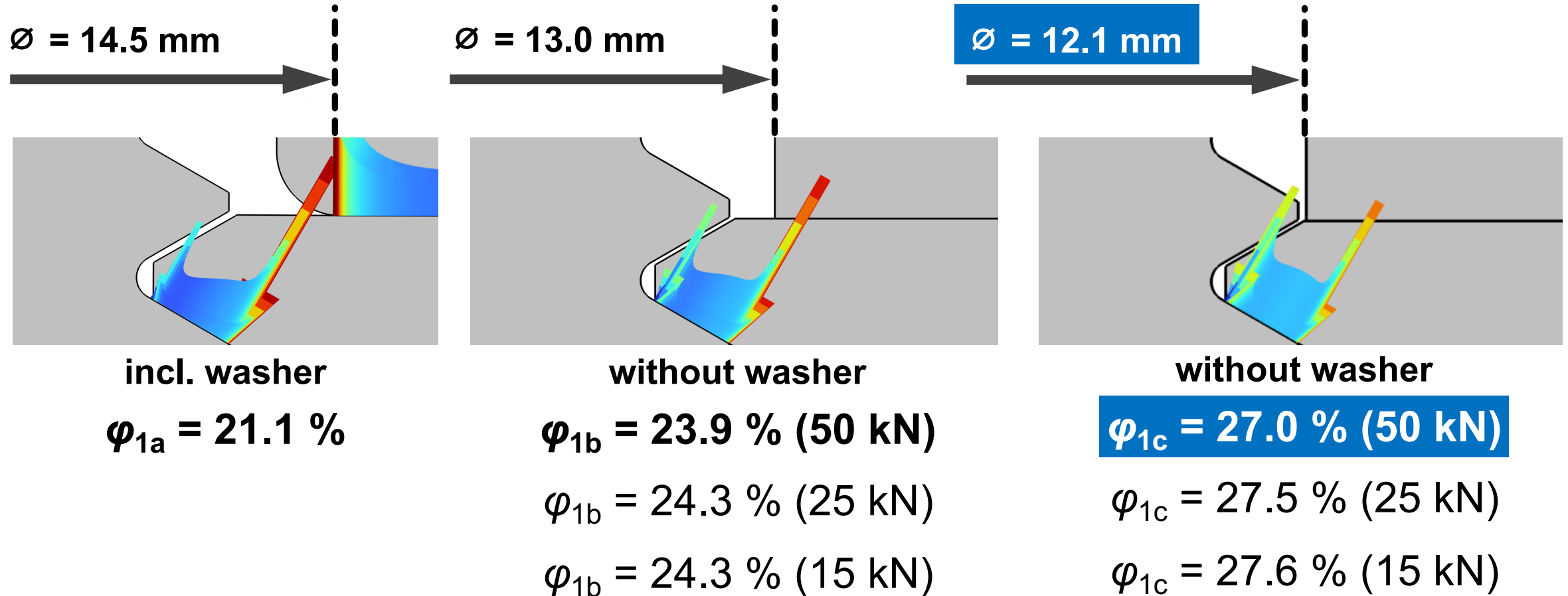

- This is an update of 29th October 2023 with an additional simulation for $\varnothing_{\text{hole}} = 12.1 \text{ mm}$.

Contact pressure at the threads for $\varnothing_{\text{hole}} = 12.1$ mm (nonlinear simulation)

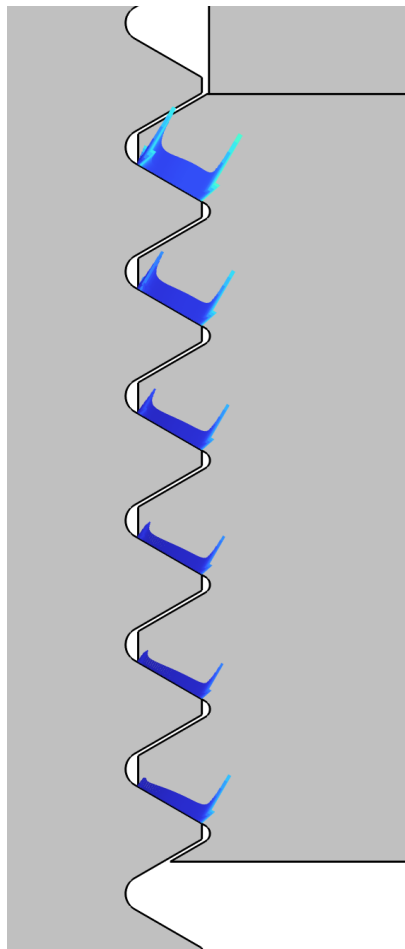

$F_{\text{preload}} = 25$ kN

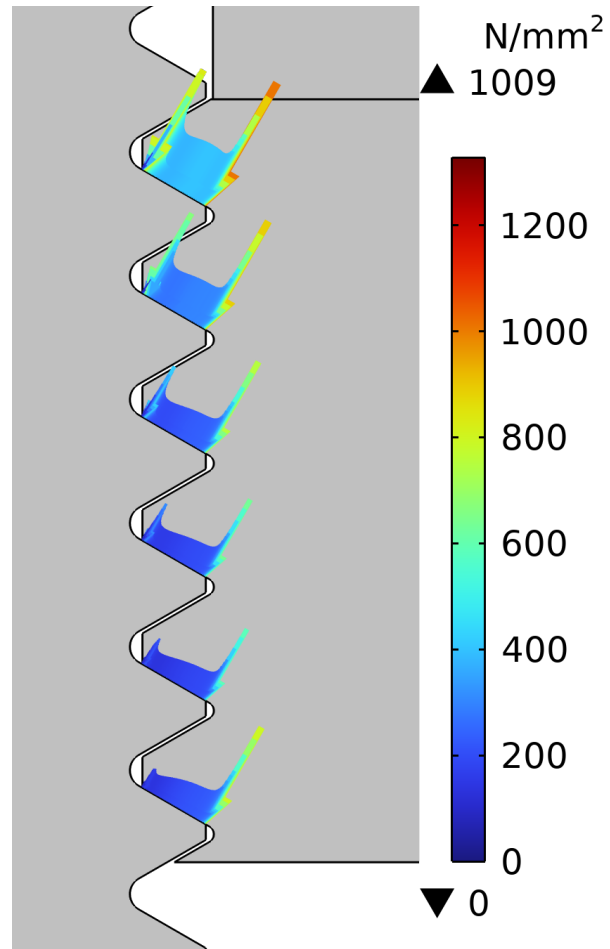

$F_{\text{preload}} = 50$ kN

contact pressure T_n in N/mm^2

- Through hole diameter of the bore:
 $\varnothing_{\text{hole}} = 12.1$ mm
- The load share of the 1st thread is:

$$\varphi_1 = 27.5 \% \quad (\text{for } 25 \text{ kN})$$

$$\varphi_1 = 27.0 \% \quad (\text{for } 50 \text{ kN})$$

- Surprisingly, the average contact pressure or load on the last (6th) thread is greater than that of the penultimate (5th) thread.

Table for the load shares (nonlinear simulations (most of them))

	Load shares of the individual threads					
note	1st	2nd	3rd	4th	5th	6th
incl. washer	21.1 %	20.5 %	16.6 %	14.0 %	12.9 %	15.0 %
without washer $\varnothing_{\text{bore}} = 13.0 \text{ mm}$	23.9 %	20.6 %	16.0 %	13.2 %	12.1 %	14.1 %
without washer $\varnothing_{\text{bore}} = 12.1 \text{ mm}$	27.0 %	20.2 %	15.4 %	12.6 %	11.5 %	13.4 %
incl. $\mu = 0.1$	22.0 %	21.0 %	16.5 %	13.5 %	11.9 %	15.0 %
nut in Alu	17.7 %	19.7 %	16.3 %	14.2 %	13.9 %	18.2 %
nut in Ti	18.7 %	19.9 %	16.4 %	14.2 %	13.7 %	17.1 %

Load distribution of different variants for 50 kN
(friction with $\mu = 0.1$ incl. washer;
nut in Alu & Titanium calculated
in linear elastic incl. washer)

Diagrams for some load shares (nonlinear simulations)

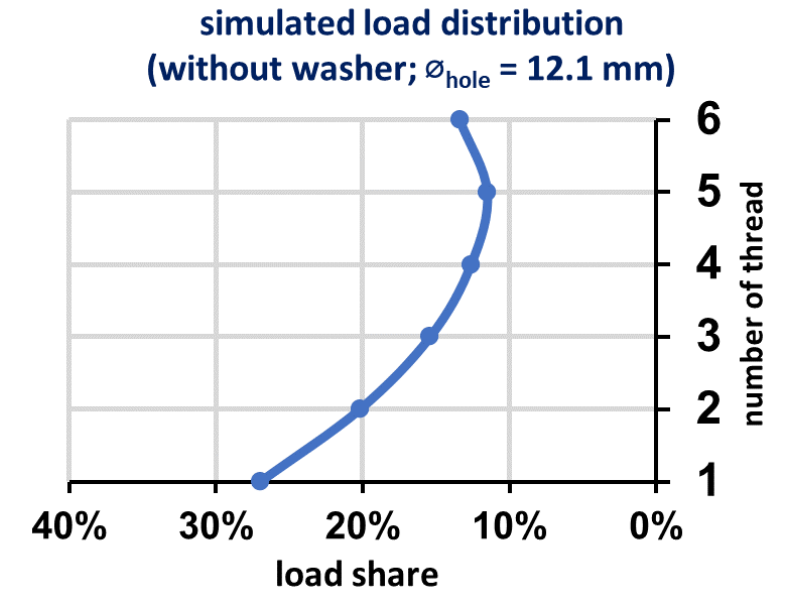
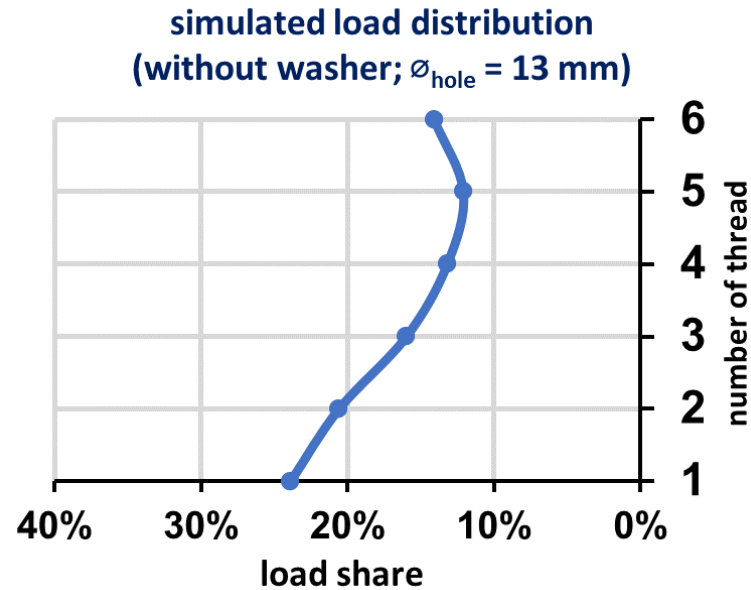
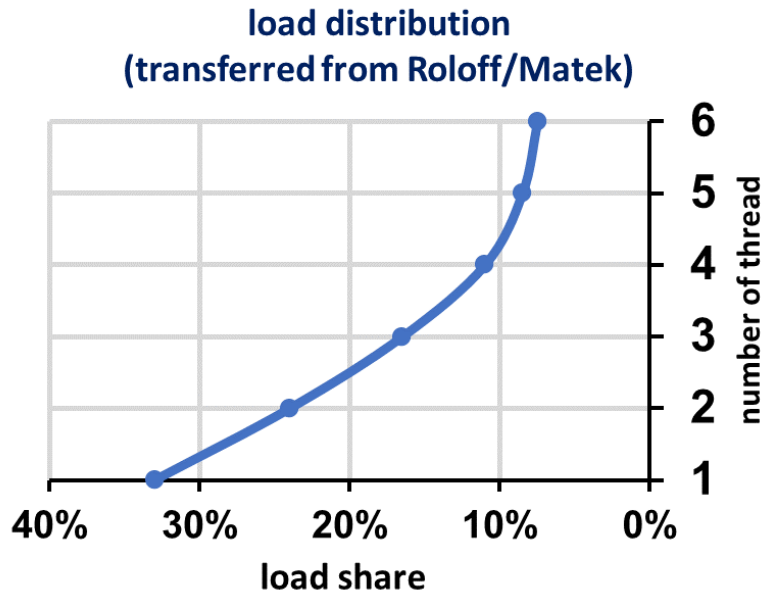

- Simulations results for a preload of 50 kN
- Load share of the first thread corresponding to the simulation without washer and $\varnothing_{\text{hole}} = 12.1 \text{ mm}$:
 $\varphi = 27.6 \%$ (15 kN)
- $\varphi^* = 27.8 \%$ (corresponding to Yang et. al. for 15 kN)

Simulation of a tension nut with expected more even load distribution

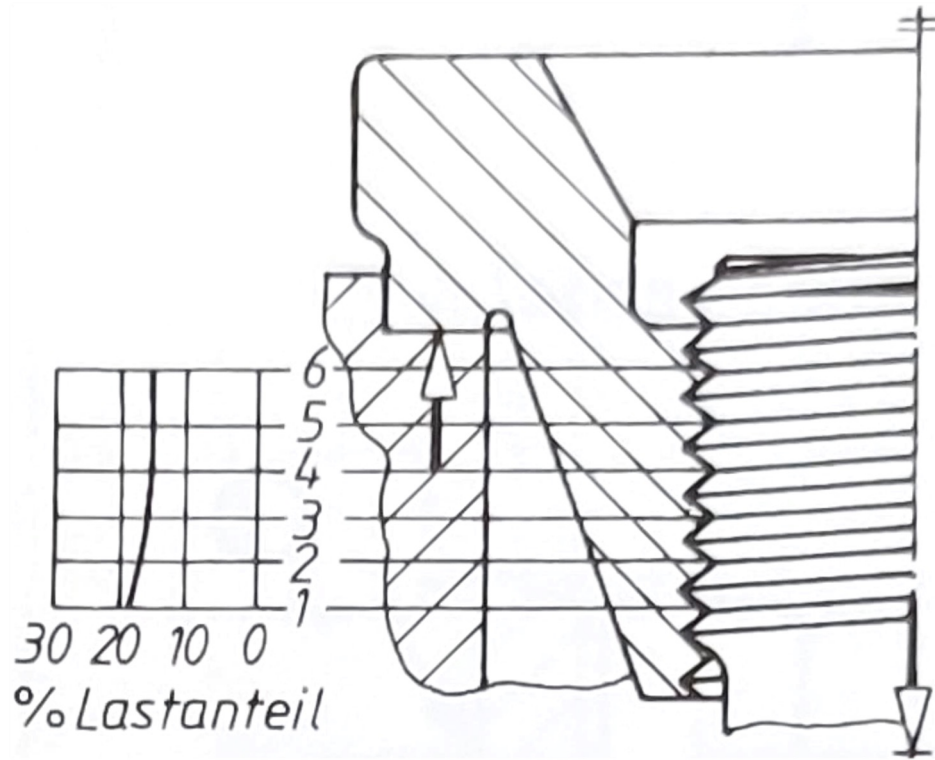

**Tension nut (in German: 'Zugmutter')
with load distribution or load share ('Lastanteil')
[source for this illustration: [3, p. 228]]**

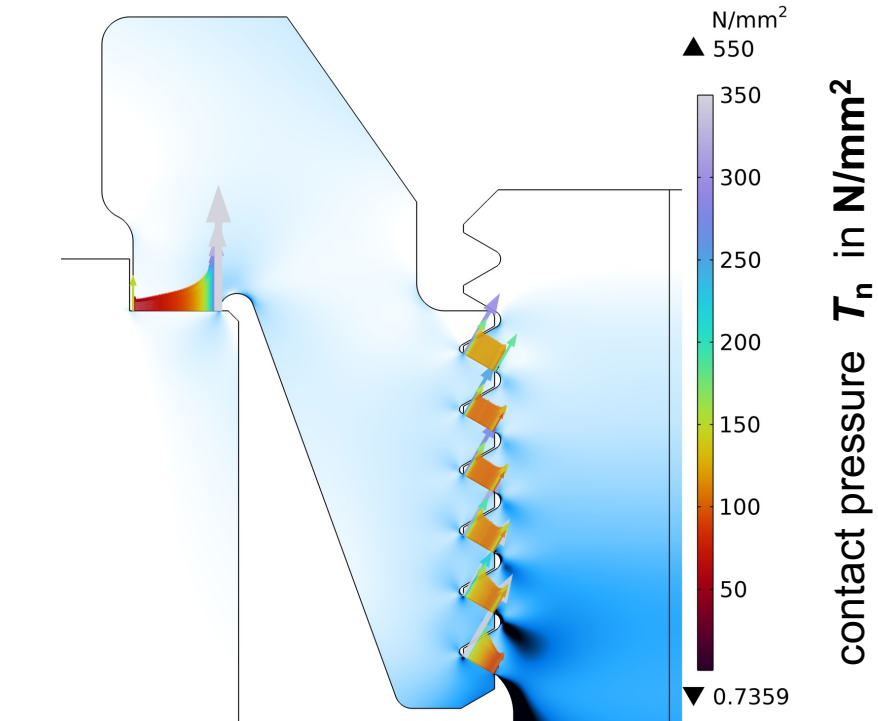

**Tension nut; linear calc. for 25 kN;
display of the contact pressure distribution
incl. illustration of the equivalent stress in the background**

Load shares of the individual threads for the simulated tension nut					
1st	2nd	3rd	4th	5th	6th
17.2 %	17.9 %	16.9 %	15.7 %	15.3 %	17.0 %

source of [3]: H. Wittel, D. Muhs, D. Jannasch and J. Voßiek, Roloff/Matek Maschinenelemente, 19th ed., Vieweg+Teubner, 2009.

Simulation of a annularly screwed-in nut; nonlinear calc. for 25 kN

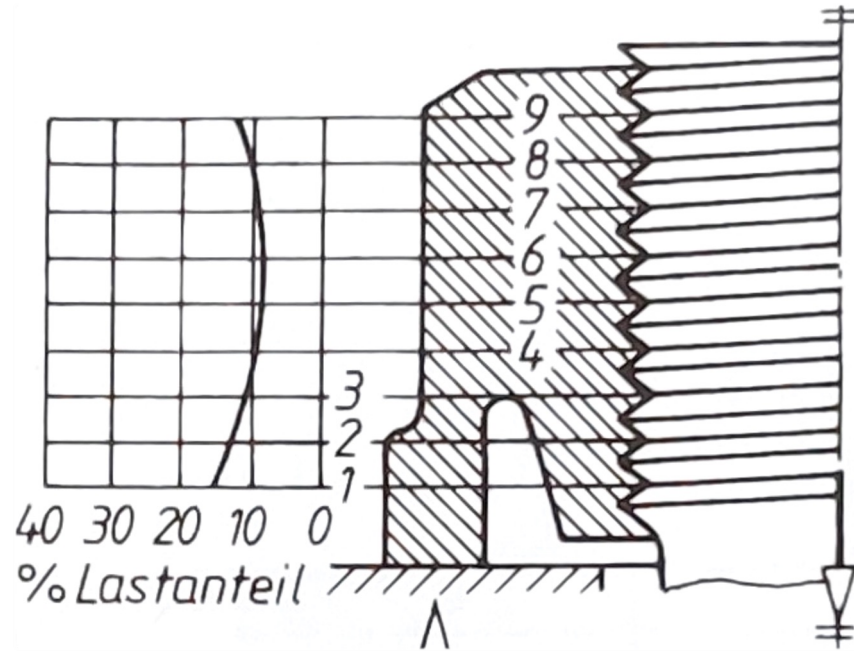

**Ring-shaped screwed-in nut
resp. annularly screwed-in nut
[source for this illustration: [3, p. 228]**

Load shares of the individual threads for the simulated annularly screwed-in nut					
1st	2nd	3rd	4th	5th	6th
11.1 %	15.1 %	13.6 %	9.96 %	9.75 %	10.7 %
7th	8th	9th			
10.2 %	9.42 %	10.3 %			

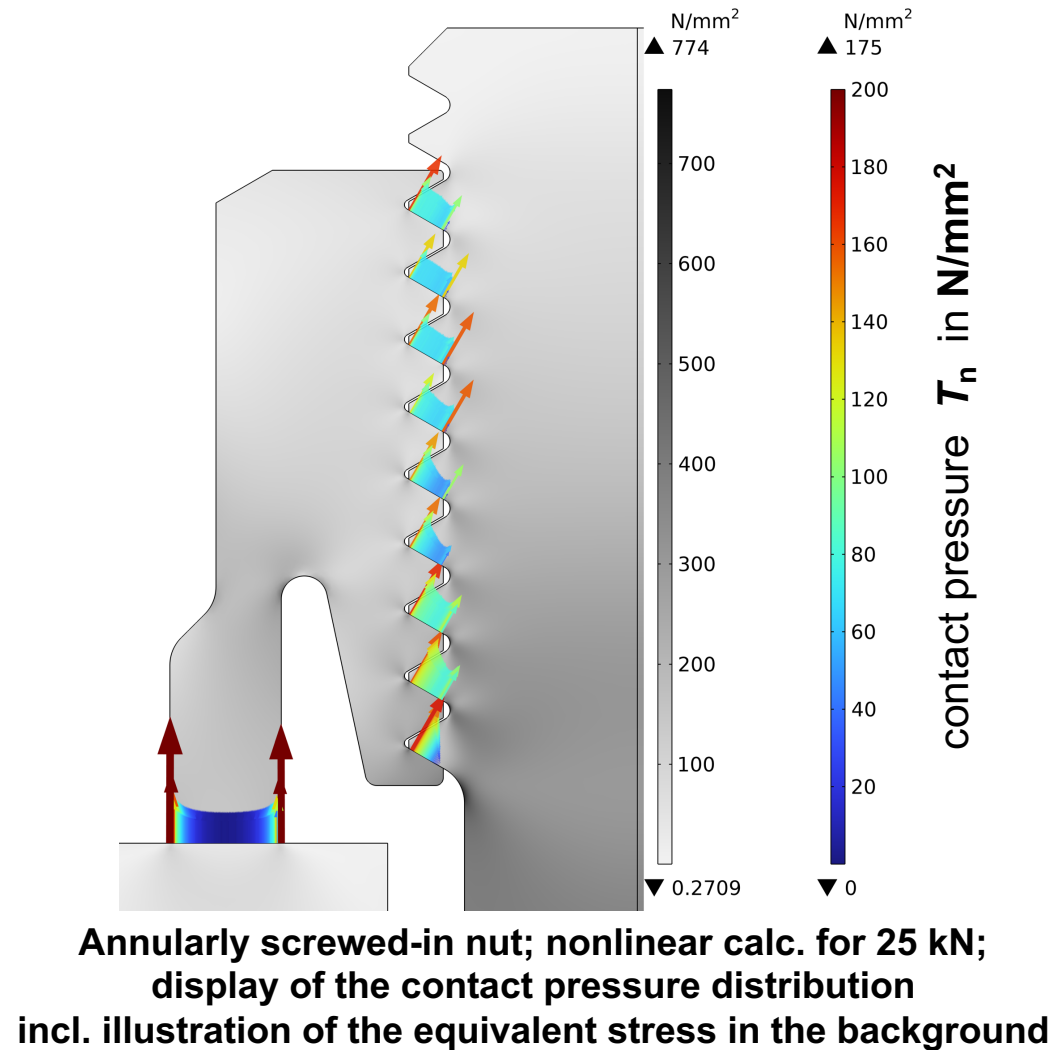

source of [3]: H. Wittel, D. Muhs, D. Jannasch and J. Voßiek, Roloff/Matek Maschinenelemente, 19th ed., Vieweg+Teubner, 2009.

Simulation of a nut with Solt-thread (nonlinear for a preload of 25 kN for steel)

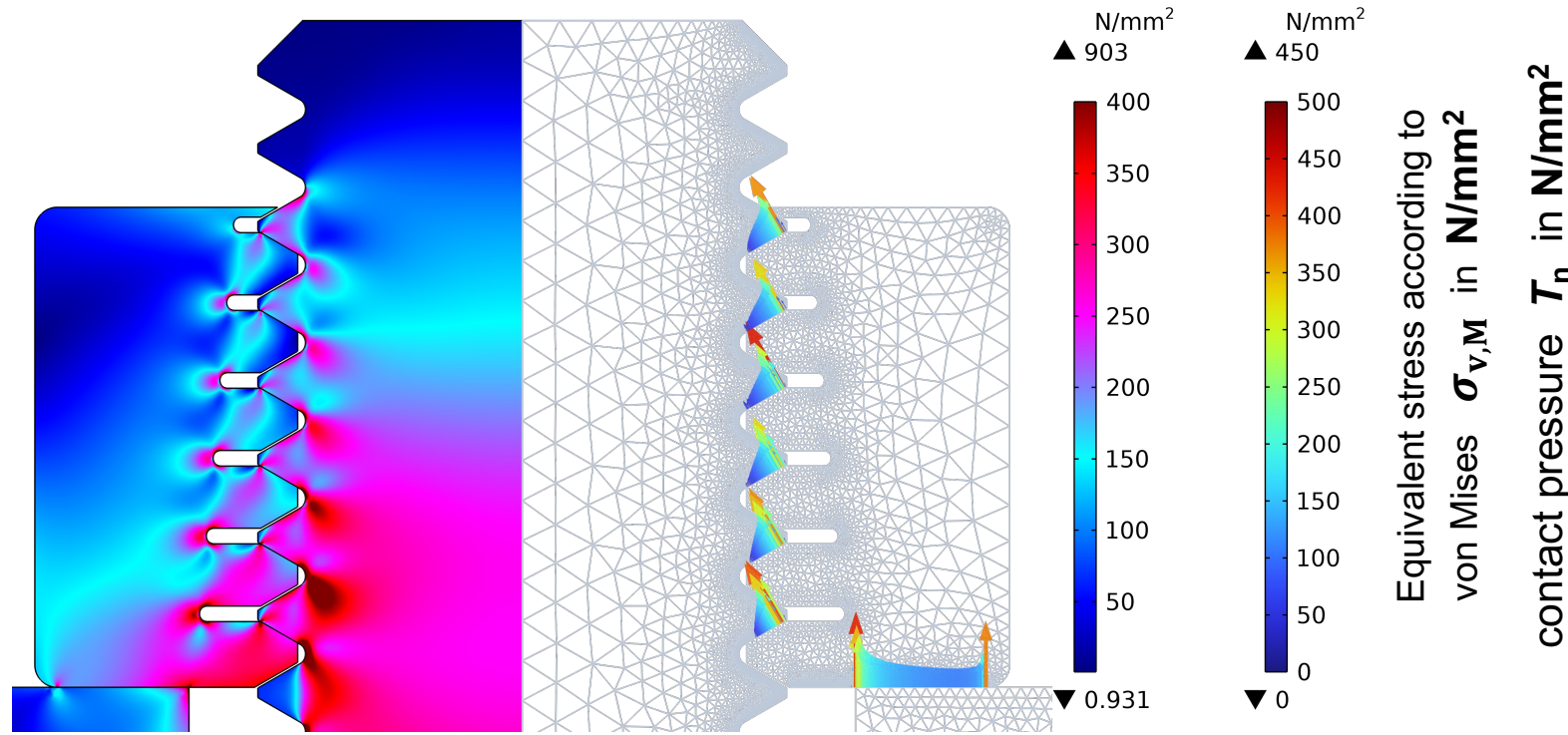

nut with Solt-thread [4]: equivalent stress (von Mises) displayed (left) and contact pressure & mesh (right half)

Load shares of the individual threads for a nut with Solt-thread corresponding to simulation					
1st	2nd	3rd	4th	5th	6th
17.6 %	17.9 %	16.8 %	15.8 %	15.2 %	16.6 %

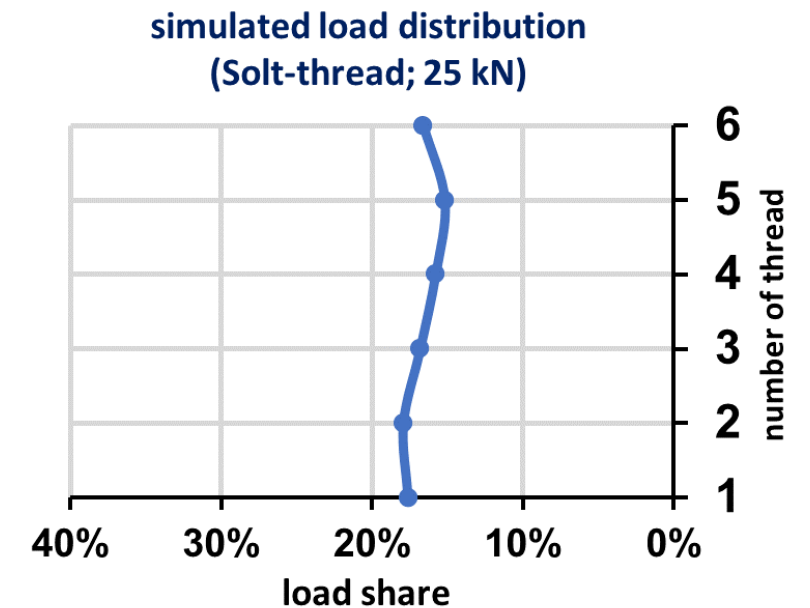

source of [4]: E. Jaquet, "Ueber eine neuartige Schraubenverbindung.", Zeitschrift: Schweizerische Bauzeitung, 1931.

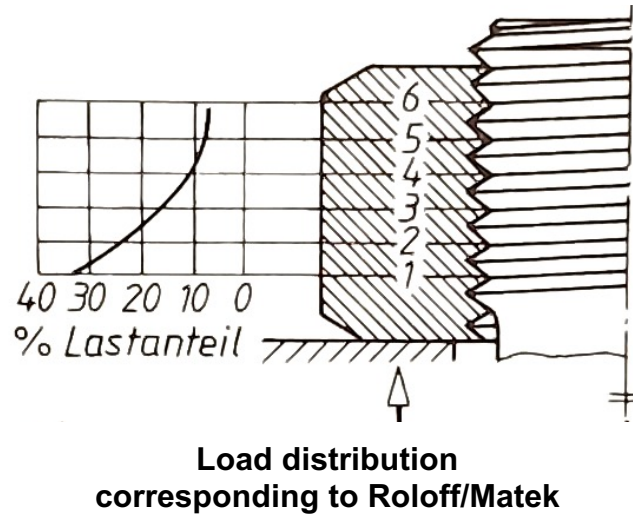

load distribution
(transferred from Roloff/Matek)

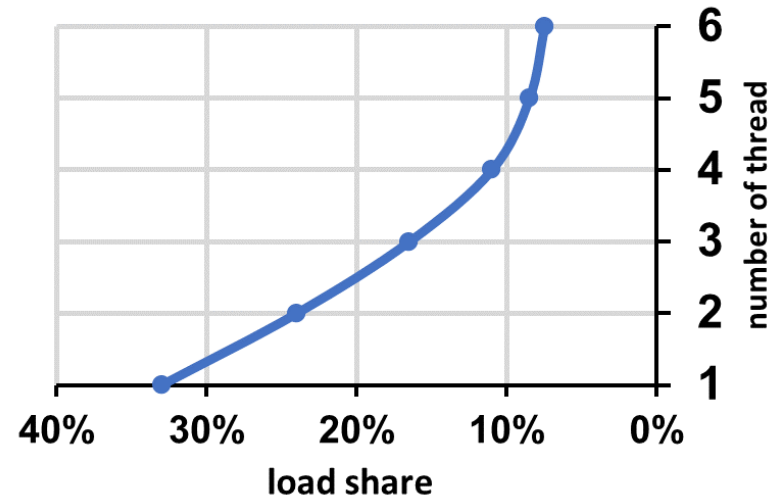

simulated load distribution
(without washer; $\varnothing_{\text{hole}} = 13 \text{ mm}$)

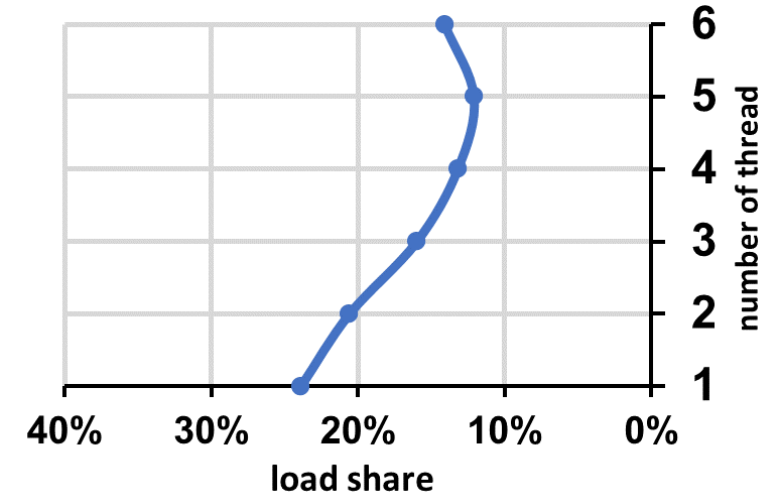

- Detailed insights into the stress distribution in the components of a screw were obtained.
- Studies comparing linear elastic considerations and geometric simplifications with omission of core fillets have shown even much stronger notch resp. stress concentration effects compared to more realistic nonlinear simulations.
- The contact pressure distribution at the metric threads simulated here in this work has shown a more uniform load distribution than values determined in other textbooks or papers. The shape of the load distribution deviates from for example the distribution presented in Roloff/Matek.