

Principal Lumped Model for Sound and Vibration Sensitivity of a Condenser Type Microphone

G. Obradovic¹, R. Christensen²

1. Hardware Architecture and Solutions, R&D, Demant, DK-2765 Smørum, Denmark.

2. Acculution ApS, DK-2650 Hvidovre, Denmark

Abstract

A condenser type pressure sensor (microphone) will have an electrical output for any displacement of the membrane relative to the backplate, which is usually but not necessarily bound to the microphone 'housing'. Typically, the microphone displacement is a result of an acoustic pressure input being different from the pressure in the rear volume, with this pressure differential acting as a force on the membrane. However, if the housing is subjected to a vibration, inertia and acoustic effects will also lead to a relative displacement of the membrane, and hence an electrical output is present. For microphones mounted in hearing aids, the latter effect will be of importance as the loudspeaker operation will invariably vibrate the hearing aid and in effect the microphone(s), and this will affect the overall stability, i.e. achievable acoustic gain, of the hearing aid. A new lumped model of a condenser type sound and vibration sensor has been developed, from which both acoustic as well as vibration sensitivity is deduced. The lumped model has been compared to the FEM simulation model, using COMSOL Multiphysics, of a generic condenser microphone, with good matching between the two.

Keywords: Condenser Microphone, Lumped Model, Acoustic, Sound, Vibration

Introduction

A hearing aid condenser microphone, like any other microphone, is essentially a vibration pickup sensor. The vibration is primarily an effect of sound waves that cause pressure variations in the air at the location of the microphone membrane. However, the sound is not the only possible vibration source responsible for membrane motion. The membrane is connected to the housing via a mechanical suspension, as well as being coupled via the acoustic-structure interaction. Vibrating the microphone housing will inevitably transfer some of the mechanical energy to the membrane via these couplings. Any differential motion between the membrane and the backplate will result in an electrical output at the microphone terminals. In fact, a microphone can be transformed into a purely vibration sensor by blocking the port through which the sound normally reaches the membrane.

While the response to the sound excitation is a desired microphone behavior, the response to vibration is usually not. For example, a microphone's response to vibration is one of the major determinants for the gain limitation in hearing aids. The receiver (loudspeaker) operation causes the hearing aid mechanics to vibrate, and this vibration is transferred to the microphones, closing the loop between the microphone and receiver, ultimately limiting the stability of the hearing aid. Note that the vibration of the hearing aid also causes sound radiation, which forms another feedback loop between the receiver and the microphone. Of course, the sound pick-up

mechanism here is the same as for the intended sound.

The importance of the vibration characterization of microphones is well known. Sources of vibration signals in microphones were investigated in [2]. The topic has received attention in the experimental approach, especially applied to miniature microphones, from [3] to the more recent publication [4]. However, to the best of the authors' knowledge, no lumped model has been presented that has explicit inclusion of the vibration characterization where the excitation is a force acting on the housing. However, a similar principal model with differential velocities has been presented for a Balanced Armature Receiver [5].

The purpose of the proposed microphone model is to be able to evaluate the sensitivity to both acoustic input and vibrational ditto in a single topology. The model can be used both to quickly evaluate the effect of design changes during microphone development phases, but also for use in the hearing aid industry, where finite element models and/or measurements give the acoustic and vibrational input to the microphone.

The lumped model has been compared with COMSOL Multiphysics simulation models for a generic condenser microphone geometry, since the few alternative models developed by the hearing aid transducer companies are known only to them, and in derived/simplified forms in the hearing aid companies, and hence the authors are bound by confidentiality. To the best of the authors'

knowledge the model presented here is significantly different though, employing direct translation of the microphone physics into elements in a lumped circuit, offering advantages regarding both logical layout and ease of implementation in electrical circuit software.

COMSOL Multiphysics Interfaces

The lumped modelling of the microphone was done via netlists in the Electrical Circuit (0D) interface. The vibroacoustic validation models were done in using the Pressure Acoustics, Frequency Domain interface with the Solid Mechanics interface, both with 2D-axisymmetry dimensions, and with an Acoustic-Structure Boundary Multiphysics coupling ensuring continuity in stress/pressure and normal velocity at physics interfaces. Rigid body motion is assumed for the membrane, housing, and backplate. A pressure can be applied to the microphone input, and a force or velocity can be applied to the housing, and the combined electrical output response can be evaluated.

Lumped Circuit Development

A simplified microphone representation will be given first, followed by principle of operation described, before finally subjecting it to the lumped modelling.

Simplified Condenser Microphone

A sketch of a simplified condenser microphone, with the most important mechanical and acoustical elements marked, is shown in Fig.1.

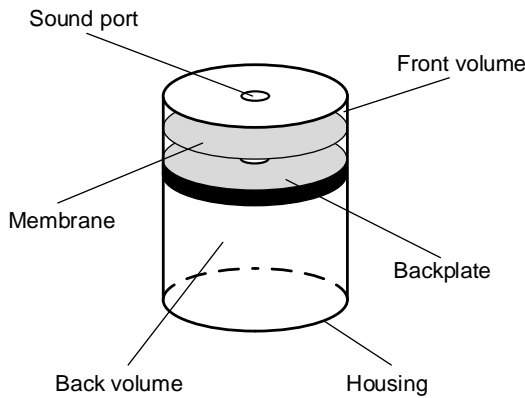

Figure 1. Simplified view of a microphone.

The intended operation of the microphone is to sense the sound pressure impinging on the membrane through the sound port. It achieves so via the resulting differential motion of the membrane relative to the backplate. The backplate is perforated (shown by a single hole in Fig.1) enabling the acoustic connection to the back volume air behind the backplate.

However, the sound excitation is not the only way to cause the membrane displacement. The

membrane is elastically connected to the housing, so any motion of the microphone housing will be transferred to the membrane, again causing the mentioned differential motion and thereby an electrical output from the microphone.

Regardless of the membrane to backplate differential motion cause, the transduction into the electrical signal is the same. In an electrostatic transducer, like the condenser microphone studied here, the membrane and the backplate form two electrodes of a capacitor. The electrodes are, most often, biased to the constant charge state, making the relative displacement between the membrane and the backplate result in a change of capacitance formed between the two, relative to the capacitance at equilibrium.

The electrical output $e(V)$, in the open circuit condition, is proportional to the relative capacitance change, as given by Eq.(1).

$$e = E_0 \frac{\Delta C}{C_0} \quad \text{Eq.(1)}$$

where E_0 is bias voltage, C_0 is equilibrium capacitance, and ΔC is capacitance variation due to varying distance between the plates caused by the applied sound pressure.

For acoustical and vibrational characterization and modelling of the microphone it is beneficial to express the microphone output as a function of the differential displacement between the membrane and the backplate, rather than of the change of capacitance.

The instantaneous capacitance, for a parallel plate capacitor, can be written as

$$C_0 + \Delta C = \varepsilon \frac{S}{b+\xi} \quad \text{Eq.(2)}$$

where S is the membrane area, b is the equilibrium plate distance, ξ is the differential displacement between the membrane and the backplate, and ε is the permittivity of air. For small displacements, $\xi \ll b$, the right hand side of Eq.(2) can be expanded into Maclaurin series while keeping only the first two terms, as shown in Eq.(3).

$$\varepsilon \frac{S}{b+\xi} \approx \varepsilon \frac{S}{b} \left(1 - \frac{\xi}{b}\right) = C_0 - C_0 \frac{\xi}{b} \quad \text{Eq.(3)}$$

The condition $\xi \ll b$ is satisfied up to large pressures, above 100 dB SPL, even in miniature microphones used in earbuds and hearing aids.

By combining Eq.(2) and Eq.(3) we arrive at the relation shown in Eq.(4).

$$\left| \frac{\Delta C}{C_0} \right| = \left| \frac{\xi}{b} \right| \quad \text{Eq.(4)}$$

Finally, using Eq.(4) to reformulate Eq.(1) in terms of the differential displacement we arrive at the relation Eq.(5) that is relevant for the following study.

$$|e| = \frac{E_0}{b} |\xi| \quad \text{Eq.(5)}$$

Therefore, observing the differential displacement is sufficient to characterize and compare sound and vibration sensitivity of a microphone. This fact will be exploited in the further text by modelling and monitoring the differential displacement, rather than the electrical output of the microphone.

For more details on this type of transducers, and many others, one can be referred to many sources, for example [1].

Note the consistent use of the term differential displacement. In common microphone analyses, focusing on the transduction of the sound energy, it is sufficient to state membrane displacement understanding that the housing with the, usually hard mounted, backplate is considered immovable while the membrane is the only moving element. Introducing the vibrational characterization entails motion of the housing with the backplate as well, so using the membrane displacement as a measure of the microphone output becomes incorrect, requiring the use of the differential motion term.

Lumped Circuit

A cross-section view of the microphone used in the modelling exercise is shown in Fig.2.

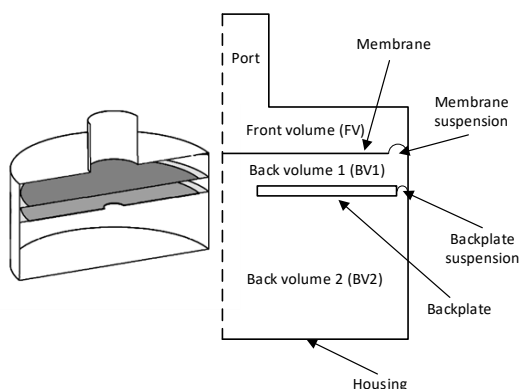

Figure 2. Cross-section (left) and axisymmetric (right) view of the microphone to be modelled.

The microphone has one hole in the backplate, as opposed to perforations that are usually used in practice. The reason for this decision is the resulting axisymmetric model that enables very fast FEM executions.

Two additions are present here compared to Fig.1. A simple hole in Fig.1, acting as the sound inlet, is replaced by a microphone port (spout), as such microphone configurations commonly exist in practice. The port can be collapsed into the opening, as in Fig.1, if necessary. The second addition is the suspension of the backplate. Suspending backplate has little to no effect in the sound pick up but can be used to modify the vibrational characteristics of a microphone.

Both membrane and the backplate are considered rigid, with the compliance entirely attributed to the suspensions around the rims of the two elements.

For the vibration sensitivity modelling we will only include the normal to membrane direction. This direction is the dominant one and engages all the acoustical and mechanical elements shown in Fig.2. The sideways motion of the microphone housing also produces an electrical output, but the effect is entirely acoustical.

Finally, both the lumped model and the COMSOL FEM were created lossless. The benefit of this approach is in identifying all resonant behavior in a microphone, without them being masked by loss effects that very pronounced in small structures like miniature microphones. Incorporating losses in the lumped model requires the inclusion of resistors and a fitting process for determining their values.

We will now build towards a complete lumped model in several steps to illustrate the subtleties within each of these. The needed details about general lumped modelling as well as transmission line modelling for arriving at the complete model are presented, although general knowledge about these topics is preferable and will aid in the reading.

The initial structural mechanics can be thought of as spring-mass system with two masses for the membrane and the housing, respectively, connected via a mechanical spring coming from the compliant nature of the membrane suspension, as shown in Fig.3. The acoustics is for now omitted, so one can think of this as a ‘vacuum’ schematic. Hence the excitation on the housing, either constant velocity or constant force. For simplicity, the backplate and its suspension are also omitted for now.

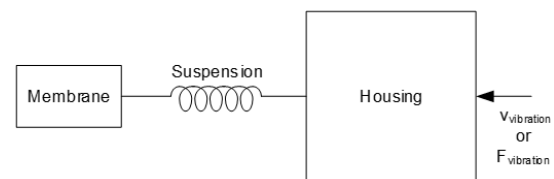

Figure 3: The schematic showing the lumped mechanical part with housing mass being excited and the connected to the membrane mass via the suspension at their edge interface.

Forces related to the individual components are simply mass times acceleration for each of the two masses, whereas the spring experiences a force of spring stiffness times the differential displacement found between the two masses. If the housing is being vibrated with a known velocity, then the actual mass of the housing need not be considered explicitly, and since the vibration sensitivity will relate the *velocity* to the electrical output (as opposed to a force related to the housing). For momentary simplicity, we will assume constant velocity excitation, so we can continue with a lumped circuit where the housing mass is ignored.

For the structural mechanics parts, a choice has been made to use so-called *impedance* models (as opposed to admittance/mobility models) throughout the electrical analogy circuits, meaning that a mass corresponds to an electrical inductance and a spring corresponds to an electrical capacitor. Likewise, mechanical forces and velocities then correspond to electrical voltages and currents, respectively. The electrical analogy circuit for the membrane being excited at its outer edges, in the direction normal to the membrane, by the housing displacement, is shown in Fig.4.

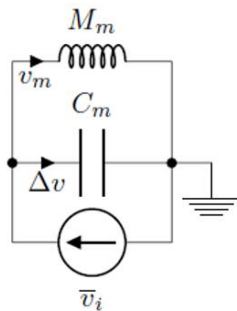

Figure 4: The electrical analogy circuit for the membrane mass and suspension being excited at the interface to the housing.

A note should be made regarding the physical sensor being three-dimensional, while the analogy circuit is essentially zero-dimensional. Normal vectors and directions in general, will have to be implicitly included in the circuit by way of the direction of current arrows, and said arrows are kept consistent throughout the analysis.

For the acoustics, it is usually sufficient to consider two lumped components, either related to a closed cavity with its internal air being purely compressed, or a mass ‘plug’ of air moving with constant velocity in its confinement with pure momentum associated. We continue with the impedance components strategy, where the cavity will be

represented via a capacitor, and a moving air mass as an inductor.

For some parts of the transducer setup, however, it is not possible to select only one of the two lumped component options, even though the part/cavity in question is seemingly a lumped entity. This happens to be the case for cavities having different velocity at two discrete opposite ends, where a transmission line model is in general needed, since both compression and momentum effects will be present as the cavity is both being compressed and displaced at once. This situation is present in the microphone setup. For such situations, one will generally have to resort to transmission line modelling, which, being a continuous type modelling, goes against the simplicity sought for our lumped model. A resolution is found by considering that a transmission line model can be described equivalently via an infinite number of distributed lumped components, and then truncated to any order that will serve the purpose. We illustrate this in Fig.5 for the rear cavity experiencing the membrane volume velocity at one end at the housing volume velocity at the other end.

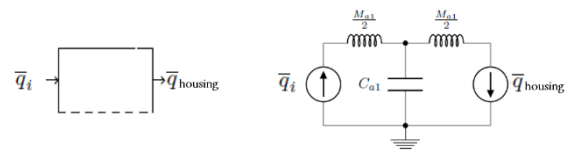

Figure 5: An acoustic cavity subjected to different velocities at either end (left), and the corresponding lumped element model (right)

The electrical analogy circuit uses a so-called Equivalent-T representation of the transmission line, where the total acoustic mass is split across two lumped inductors and compressional effects are included in a center capacitor, with three components having frequency-constant component values.¹ This approximation to a transmission line should suffice for all known condenser transducers in the audible frequency range.

From here, a more complete analogy circuit can then be built for the geometry schematic outlined in Fig.6, resembling an axisymmetric condenser microphone. Such a very simplified microphone is suitable to demonstrate the integration of the sub models shown above.

We combine structural mechanics modelling from Fig.4 with acoustic modelling from Fig.5, complemented with transformers to provide the fluid to structure coupling. The result is the electrical analog shown in Fig.7.

¹ The Equivalent-T circuit (central difference approximation), as well as the alternative Equivalent-II circuit (one-sided difference approximation), can

completely accurately describe the end-point variables of a traditional matrix-form transmission line model.

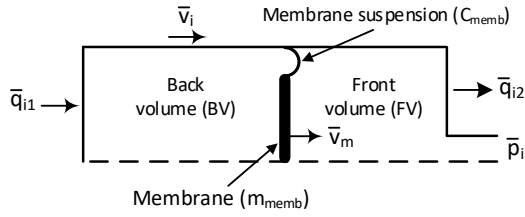

Figure 6: The simplest microphone representation, suitable for combining models from Fig.4 and Fig.5

The two transformers, each responsible for one side of the membrane to air coupling, have the same transformation ratio being equal to the membrane area S_{memb} . The impedance Z_{port} in Fig.7 takes the port impedance into account.

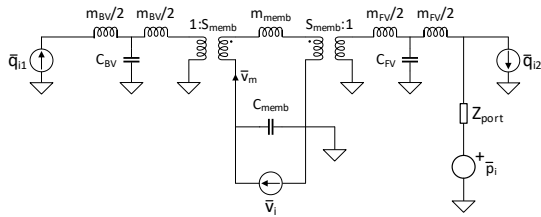

Figure 7. Electrical analog of the structure shown in Fig.6.

The input sound pressure p_i is injected towards one end of the transducer, and housing volume velocity excitations q_{i1} and q_{i2} are injected via current sources in the acoustic domain.

Note the separation of the vibration source in Fig.7 into three separate ones. One is the housing velocity v_i , while the other two are the two mentioned volume velocities, q_{i1} and q_{i2} , respectively. Such representation helps in understanding the effects that the housing motion has both on the structural and acoustical elements.

For an alternative viewpoint, the entire vibroacoustic domain can be represented entirely via a mechanical schematic, as shown in Fig. 8.

We will now expand on the model from Fig.7 and finalize the electrical analog circuit of the structure shown in Fig.2 with all elements included. The final electrical analog circuit is shown in Fig.9. Parts of the circuit are marked and labeled as the mechanical and acoustical elements in the microphone structure shown in Fig.2.

First, we have added the backplate of mass m_{BP} with its suspension of compliance C_{BP} . A suspended backplate has been considered in some prior works, for example in [6], but not in the case of vibration excitation, where the backplate acts as a radiator, just like the membrane. Hence the addition, in our model, of the two transformers assigned to the backplate, both with the same transformation ratio

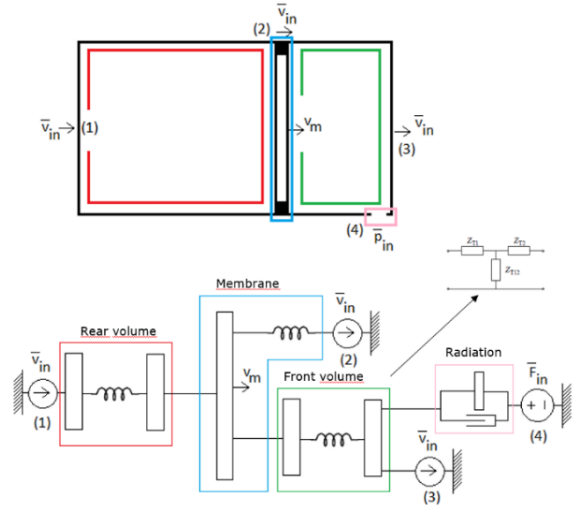

Figure 8: The overview of the axisymmetric transducer with an equivalent mechanical network.

equal to the area of the backplate S_{BP} . The impedance of the backplate hole is represented by the inductor m_{BP_hole} . The end effects on both sides of the hole were calculated from [7] using the ratio of the hole and microphone radii, with the end effects included in the single inductance m_{BP_hole} . The presence of the backplate separates the back volume into two, as shown in Fig.2. Hence the two T-networks, representing each portion of the back volume.

Second, we have unified the vibration source acting on the microphone housing, from three separate ones in Fig.7, into one in Fig.9. The source can be either a constant force F_{vib} distributed across the housing mass or a constant velocity v_{vib} , both causing translational motion of the microphone in the direction normal to the membrane. Since the force is now an excitation option, the housing mass $m_{housing}$ is introduced into the circuit. Unifying the vibration sources enables easy switching between the force and velocity excitations and ensures that all the mechanical parts that vibrate with the same velocity indeed behave like in the lumped circuit as well.

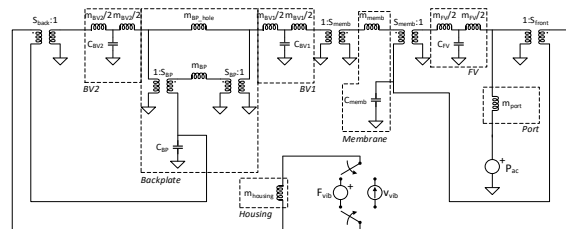

Figure 9: The final electrical analog of the microphone shown in Fig.2.

Having the explicit notion of mechanical sources required separation of the acoustical and mechanical domains in the circuit. Instead of the

two equivalent volume velocity sources in Fig.7, we have introduced two transformers, the leftmost and the rightmost in Fig.9, to handle the coupling of the housing to the internal air. Note the different transformation ratios S_{back} and S_{front} , due to the choice of the port location, resulting in $S_{front} < S_{back}$.

Finally, Z_{port} is represented by the inductance m_{port} containing both the inductance of the port and end correction toward the front volume, again using the result from [7]. The port is terminated with the pressure release boundary condition; hence no radiation impedance is present. The radiation impedance is not relevant for the microphone model, it can be considered an external component. In microphone integration into devices, it is replaced by acoustic load created by the actual inlet.

The microphone from Fig.2 was dimensioned so it reasonably represents a miniature microphone. The dimensions, in mm, are shown in Fig.10.

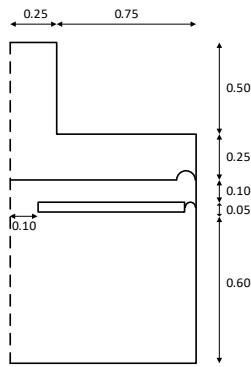

Figure 10: Relevant chosen microphone dimensions (mm).

The resulting values of the lumped elements in the circuit in Fig.9 are shown in Tab.1. The surface areas, S_{back} , S_{front} , S_{BP} , and S_{memb} are calculated directly from the dimensions. All the acoustic compartments (front volume and two back volume sections) are T-networks, as in Fig.5, and were also calculated directly from the dimensions as air masses and compliances.

The values of the structural elements, masses and compliance were read or calculated from the COMSOL simulation, presented in the next section. The masses were formed by adjusting the material density so, for the given geometry, they have reasonable mutual relation. The compliances C_{memb} and C_{BP} , for membrane and backplate respectively, were calculated from the known masses and identified resonances frequencies from a COMSOL simulation run in vacuum condition.

	Value	Unit
S_{back}	$3.14 \cdot 10^{-6}$	m^2
S_{front}	$2.83 \cdot 10^{-6}$	m^2
S_{BP}	$2.54 \cdot 10^{-6}$	m^2
S_{memb}	$2.84 \cdot 10^{-6}$	m^2
m_{BV1}	19.26	kg/m^4
m_{BV2}	115.55	kg/m^4
m_{FV}	48.14	kg/m^4
m_{BP_hole}	$7.48 \cdot 10^3$	kg/m^4
m_{port}	$3.93 \cdot 10^3$	kg/m^4
m_{memb}	$7.63 \cdot 10^{-8}$	kg
m_{BP}	$2.80 \cdot 10^{-5}$	kg
$m_{housing}$	$3.95 \cdot 10^{-5}$	kg
C_{BV1}	$2.21 \cdot 10^{-15}$	m^3/Pa
C_{BV2}	$1.32 \cdot 10^{-14}$	m^3/Pa
C_{FV}	$5.52 \cdot 10^{-15}$	m^3/Pa
C_{BP}	$8.04 \cdot 10^{-5}$	m/N
C_{memb}	$6.60 \cdot 10^{-4}$	m/N

Table 1: Values of lumped elements in circuit rom Fig.9, for dimensions shown in Fig.10.

Validation

The comparison between the lumped element circuit and COMSOL results will be done for the pressure excitation at the port location and for constant force excitation of the microphone housing. We will demonstrate individual displacement of all three structural elements, the membrane, the housing and the backplate. This allows for detailed comparison between the results, without a risk that a detail may be lost in combining the result, such as directly calculating the membrane to backplate differential displacement.

The frequency range is from 1kHz to 100kHz. Towards low frequencies, below its fundamental resonance, the system is simply stiffness controlled, hence all relevant behavior is captured in this range.

With pressure exciting the microphone, a constant pressure is applied at the port location, shown as the voltage source in Fig.9. In the COMSOL simulation the uniform pressure is applied at the port face. The results comparison is shown in Fig.11.

With force exciting the microphone, a constant force is applied to the microphone housing, so it results in translator motion in the direction normal to the membrane. The results comparison is shown in Fig.12.

All the resonant behavior is captured in the lumped model. The first shown resonant behavior takes place at 300Hz-500Hz and is a result of the backplate-suspension-housing interaction.

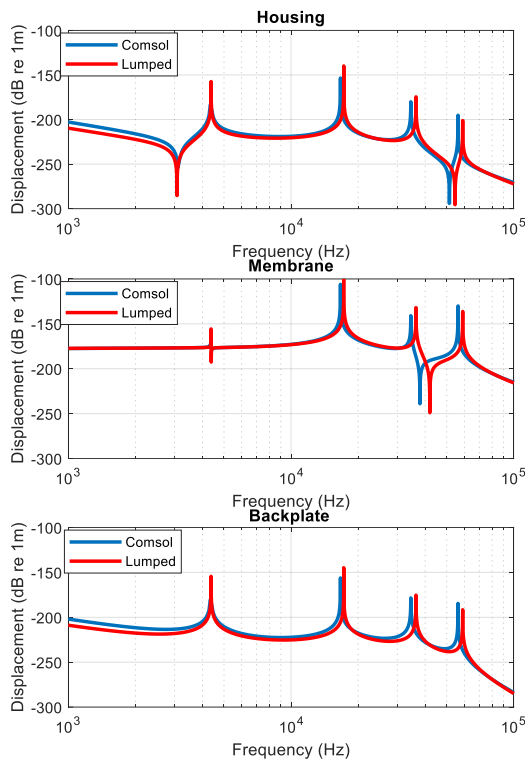

Figure 11: Comparison between the lumped element (red) and COMSOL (blue) results in housing displacement (top), membrane displacement (middle), and backplate displacement (bottom). The constant pressure is applied at the microphone port.

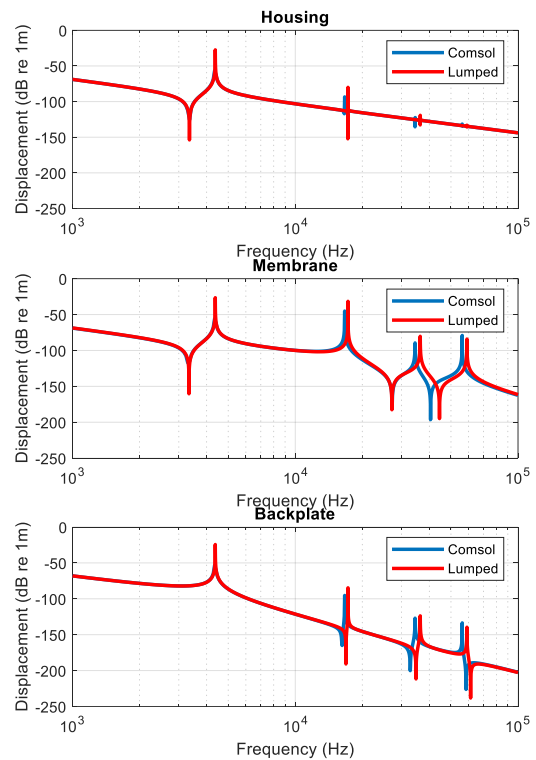

Figure 12: Comparison between the lumped element (red) and COMSOL (blue) results in housing displacement (top), membrane displacement (middle), and backplate displacement (bottom). The constant force is applied to the microphone housing.

The numerical deviation at low frequencies in the pressure excitation is due to imprecise acoustic compliances. The deviation is not present in the vibration excitation. The reason is that with the vibration excitation of the housing the air compartments behave largely as moving masses, see Fig.5, and the dominant compliances are the structural one, which were accurately determined.

Conclusion

A new lumped model has been developed for a condenser microphone that has both a traditional pressure and a vibrational input in the form of a velocity or a force. The associated electrical output is a result of both acoustical and mechanical inputs, as is relevant for hearing aids. The lumped model has been validated against a numerical model in COMSOL Multiphysics. Additions to this principal lumped model can be made such as better area scaling in the transformers, more mass components in the circuit, as well as the inclusion of sideways vibration excitation.

References

[1] M. Kleiner, "Electroacoustics", Boca Raton, CRC Press, 2013

[2] J.D. Walsh, "Vibration Signals In Sub-Miniature Microphones: Prediction And Measurement", Dissertation, Binghamton University, State University of New York, 2021

[3] M. Killion, "Vibration Sensitivity Measurement on Subminiature Condenser Microphones", J. Acoust. Soc. Am., 23(2), 121-127, 1975

[4] Charles B. King and Chris Monti, "Microphone vibration sensitivity: what it is, why it is important, and how to measure it", 183rd Meeting of the Acoustical Society of America, 2022

[5] Christensen R., "Lumped Element Modeling of Transducers", audioXpress, March 2023

[6] Josué Esteves, et al. "Lumped-parameters equivalent circuit for condenser microphones modeling", J. Acoust. Soc. Am., 142, p. 2121-2132, 2017

[7] F. C. Karal, "The Analogous Acoustical Impedance for Discontinuities and Constrictions of Circular Cross Section", J. Acoust. Soc. Am., p. 327-334, 1952